

Steinmeyer Mechatronik GmbH

Precision Stages and Systems for Vacuum

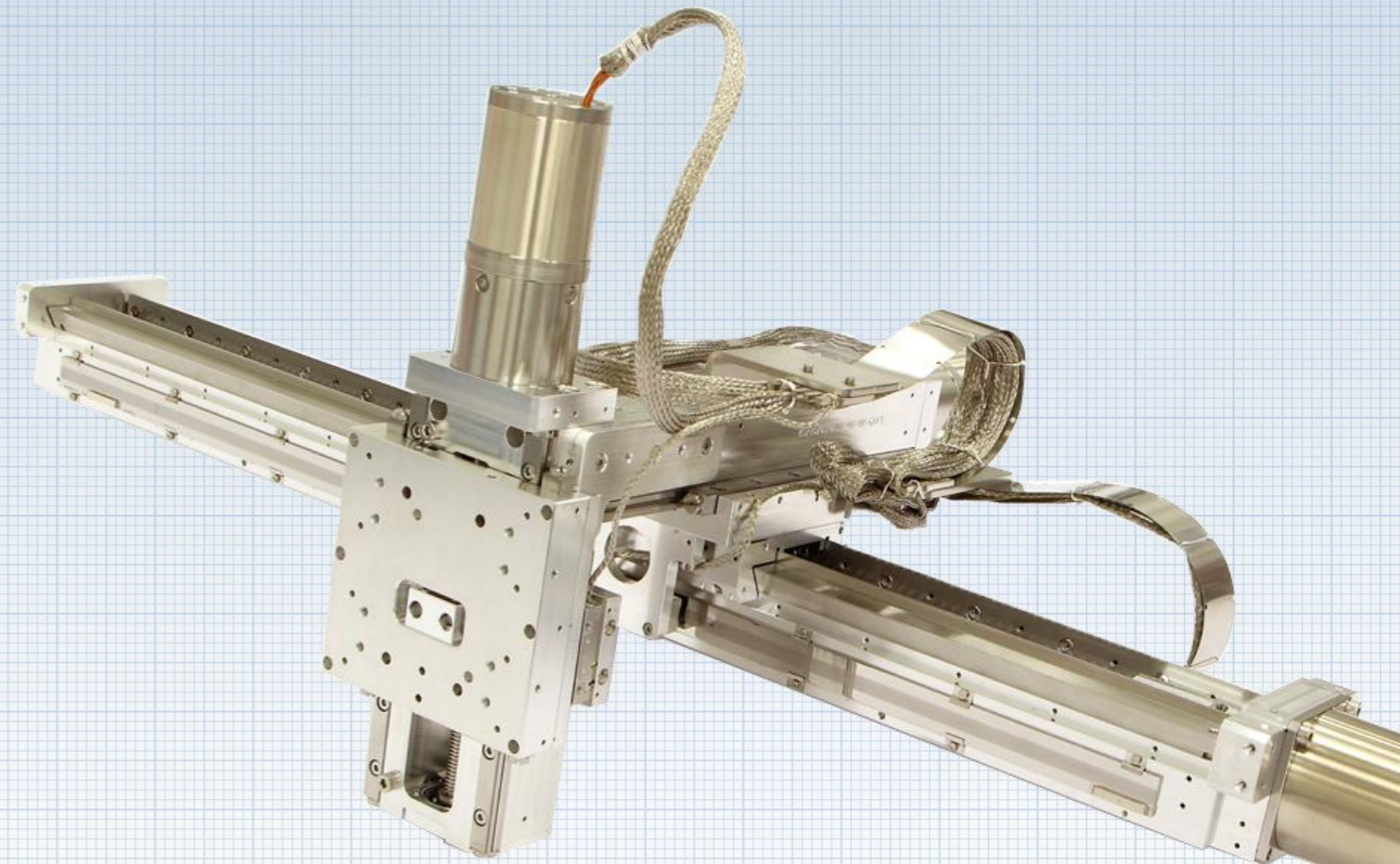

The Steinmeyer Group

- Three Competence Centers. Worldwide over 650 employees.
- High-precision ball screws for industrial applications and aerospace
- High-precision positioning solutions
- High-precision metrology
- Facilities in Germany and the USA

Steinmeyer Mechatronik GmbH

- Competence center for positioning solutions and mechatronic systems
- 100 highly motivated and special skilled employees in Dresden
- Over 140 years experience in mechanical design and production
- Innovative designs for a variety of applications
- Three shift operation in production

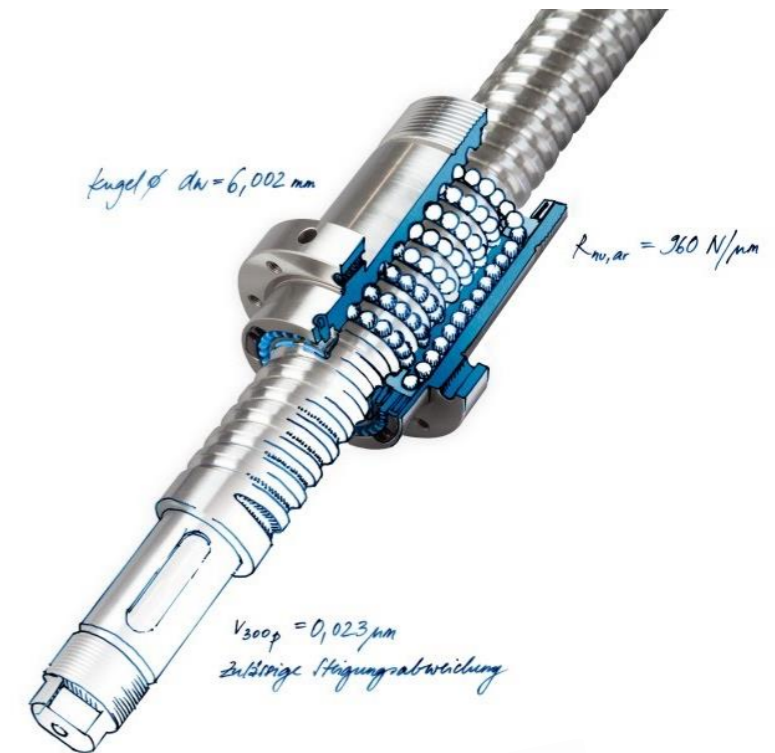

What are we offering?

- **Stages, Assemblies, Systems**

Catalogue Stages, Custom Designs

- **OEM Design and Manufacturing**

We design, manufacture and test mechatronic assemblies for a wide variety of applications.

- **All-in-one Process**

We carry out the whole design and production process under one roof in our factory in Dresden, Germany.





Assembly and test in our Clean Room

Vacuum Systems and Stages



Vacuum Linear Stages

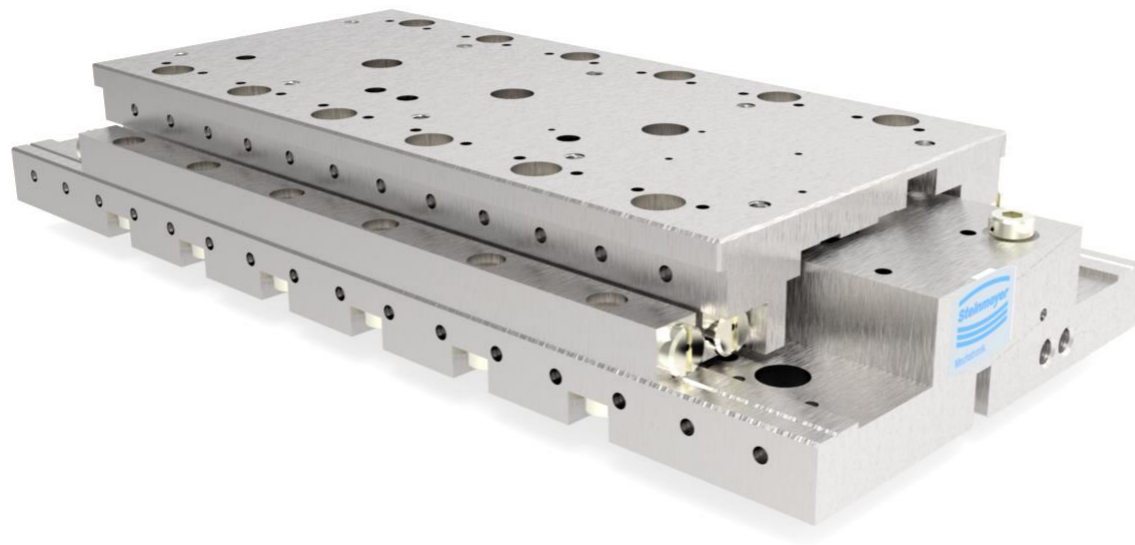

Application: scanning of samples

Benefit: fast positioning in UHV, also vertically

Features: positioning with extreme resolution,
very slim, with internal motor, magnet free

- Vacuum: all pressure ranges HV / UHV down to 10^{-11} mbar
- Magnetism: magnetic / low magnetic / magnet free
- Lubrication: liquid down to 10^{-8} mbar / dry lube down to 10^{-11} mbar
- max. bake-out temperature: 120°C

Technical Data

- Stroke: 40mm
- Repeatability: $\pm 0,4\mu\text{m}$
- Load: 2kg horizontally, 1kg vertically
- Velocity: 100mm/s

Components

- Motor: Nanomotion
- Feedback: Linear 5nm...100nm
- Guide: Cross Roller Stainless Steel, Hybrid, optionally Ceramics
- Controller: Galil

Application: fast transport stage

Benefit: high life time despite dry lube

Features: dry lube ball screw drive

- Vacuum: all pressure ranges HV / UHV down to 10^{-11} mbar
- Magnetism: magnetic
- Lubrication: liquid down to 10^{-8} mbar / dry lube down to 10^{-11} mbar
- max. bake-out temperature: 120°C

Technical Data

- Stroke: 100mm, 200mm, 500mm
- Repeatability: $\pm 4\mu\text{m}$ SM, $\pm 10\mu\text{m}$ dry SM open loop
- with Feedback $\pm 0,5\mu\text{m}$
- Load: 5kg horizontally, 1kg vertically
- Velocity: 50mm/s

Components

- Motor: Stepper Motor, Ball Screw, (Lead Screw)
- Feedback: Linear 100nm
- Guide: Stainless Steel Hybrid Recirculating Ball Guides
- Controller: FMC2, Galil

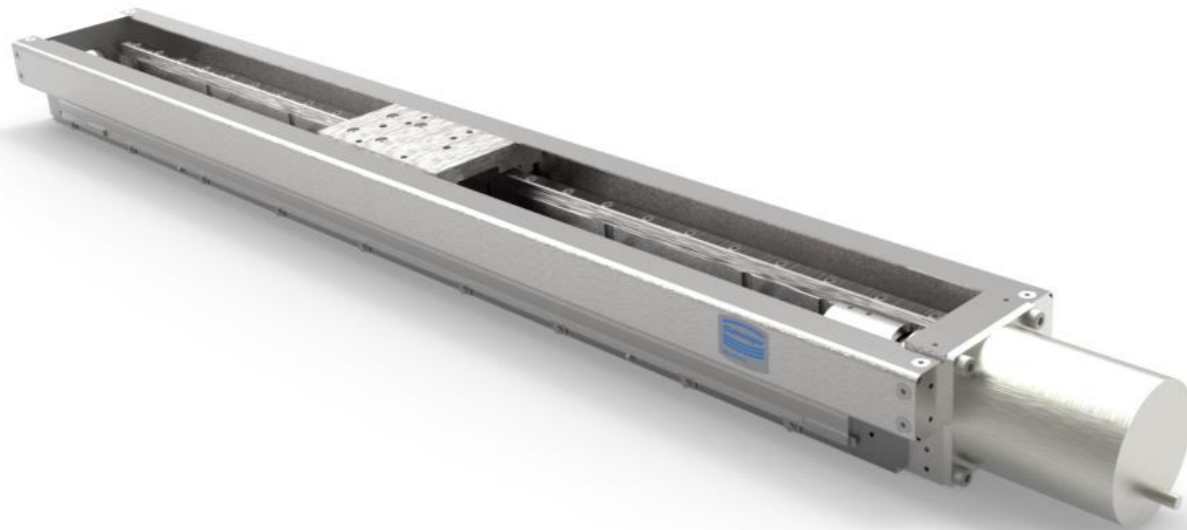

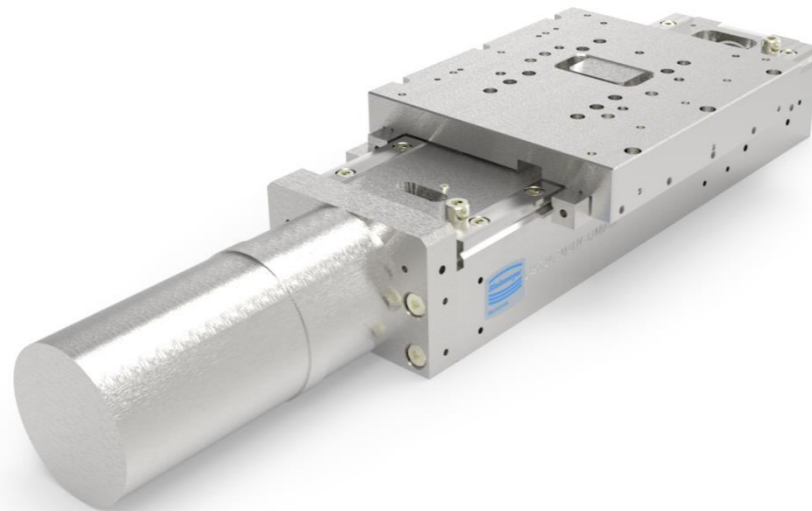

Version with Gear Box

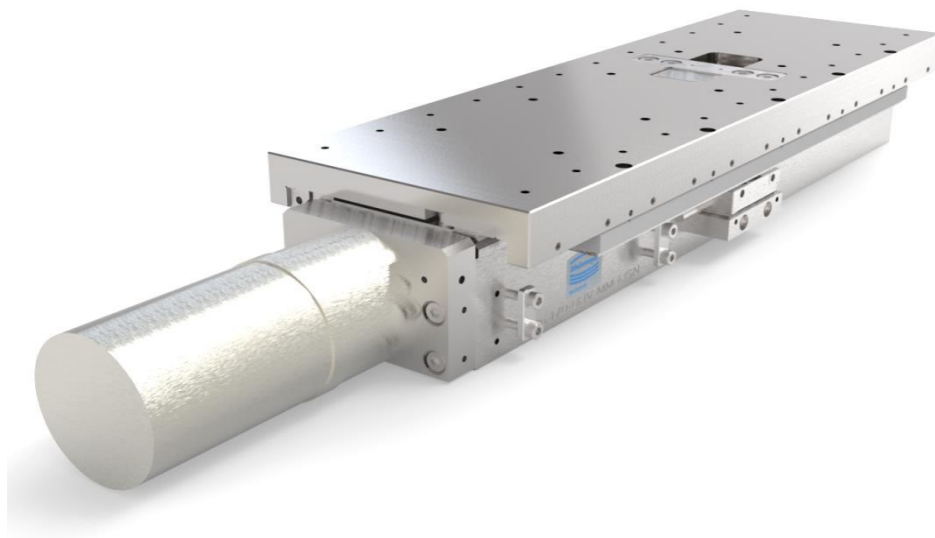

Version with Gear Box and Extra Long Slider

Application: transport stage, scanning stage

Benefit: high life time despite dry lube

Features: lead screw with dry lube or ball screw with liquid lube

- Vacuum: all pressure ranges HV / UHV down to 10^{-11} mbar
- Magnetism: magnetic
- Lubrication: liquid down to 10^{-8} mbar / dry lube down to 10^{-11} mbar
- max. bake-out temperature: 120°C

Technical Data

- Stroke: 5mm, 10mm, 40mm, 80mm
- Repeatability: $\pm 4\mu\text{m}$ SM, with Feedback $\pm 0,5\mu\text{m}$
- Load: 4,5kg horizontally or vertically
- Velocity: 5mm/s

Components

- Stepper Motor, (Ball Screw), Lead Screw
- Feedback: Open Loop or Linear Scale 100nm
- Guide: Cross Roller Stainless Steel, Hybrid
- Controller: FMC, Galil



Extra Wide Version

Application: transport stage, scanning stage for high loads

Benefit: high life time despite dry lube

Features: lead screw with dry lube or
ball screw with liquid lube

- Vacuum: all pressure ranges HV / UHV down to 10^{-11} mbar
- Magnetism: magnetic
- Lubrication: liquid down to 10^{-8} mbar / dry lube down to 10^{-11} mbar
- max. bake-out temperature: 120°C

Technical Data

- Stroke: 5mm, 10mm, 40mm, 80mm
- Repeatability: $\pm 4\mu\text{m}$ SM, with Feedback $\pm 0,5\mu\text{m}$
- Load: 20kg horizontally or vertically
- Velocity: 5mm/s

Components

- Motor: Stepper Motor, (Ball Screw), Lead Screw
- Feedback: Open Loop or Linear Scale 100nm
- Guide: Cross Roller Stainless Steel, Hybrid
- Controller: FMC, Galil

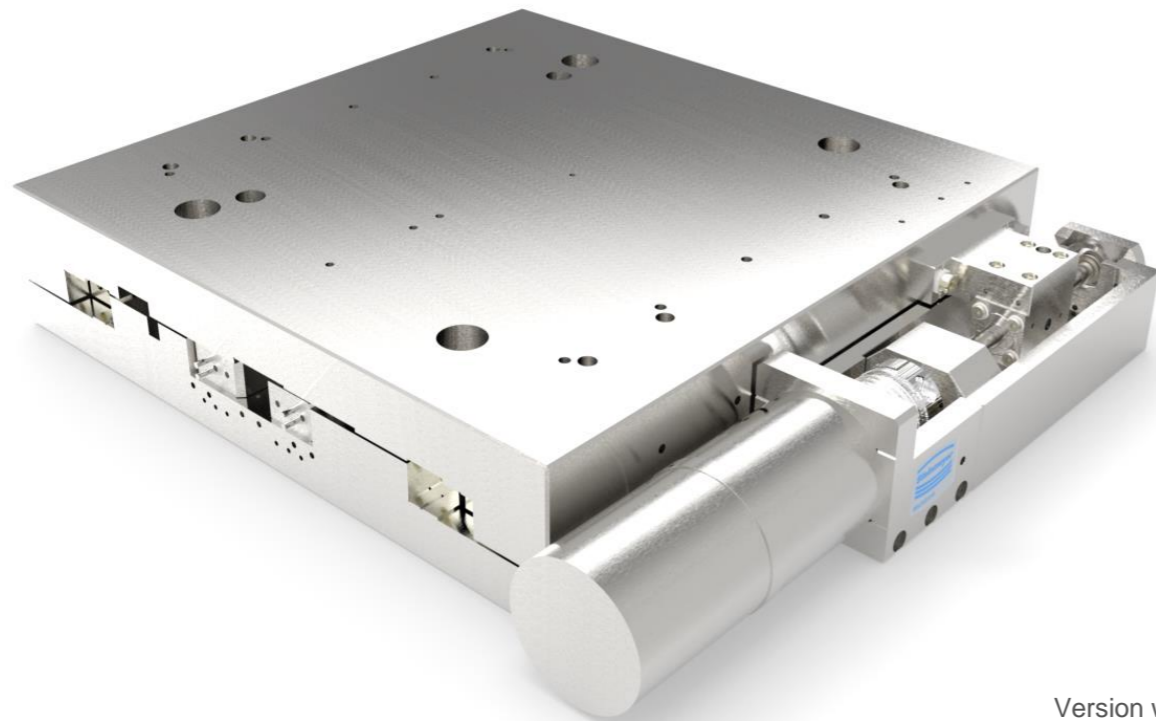

Version with Gear Box



Version with Aperture and Gear Box

Application: transport stage, scanning stage for high loads

Benefit: high life time despite dry lube

Features: lead screw with dry lube or, ball screw with liquid piezo brakes for nm-stability

- Vacuum: all pressure ranges HV / UHV down to 10^{-11} mbar
- Magnetism: magnetic
- Lubrication: liquid down to 10^{-8} mbar / dry lube down to 10^{-11} mbar
- max. bake-out temperature: 120°C

Technical Data

- Stroke: 10mm, 50mm, 100mm
- Repeatability: $\pm 4\mu\text{m}$ SM, with Feedback $\pm 0,5\mu\text{m}$
- Load: 10kg horizontally, 2kg vertically
- Velocity: 5mm/s

Components

- Stepper Motor, (Ball Screw), Lead Screw
- Feedback: Open Loop or Linear Scale 100nm
- Guide: Cross Roller Stainless Steel, Hybrid
- Controller: FMC2, Galil

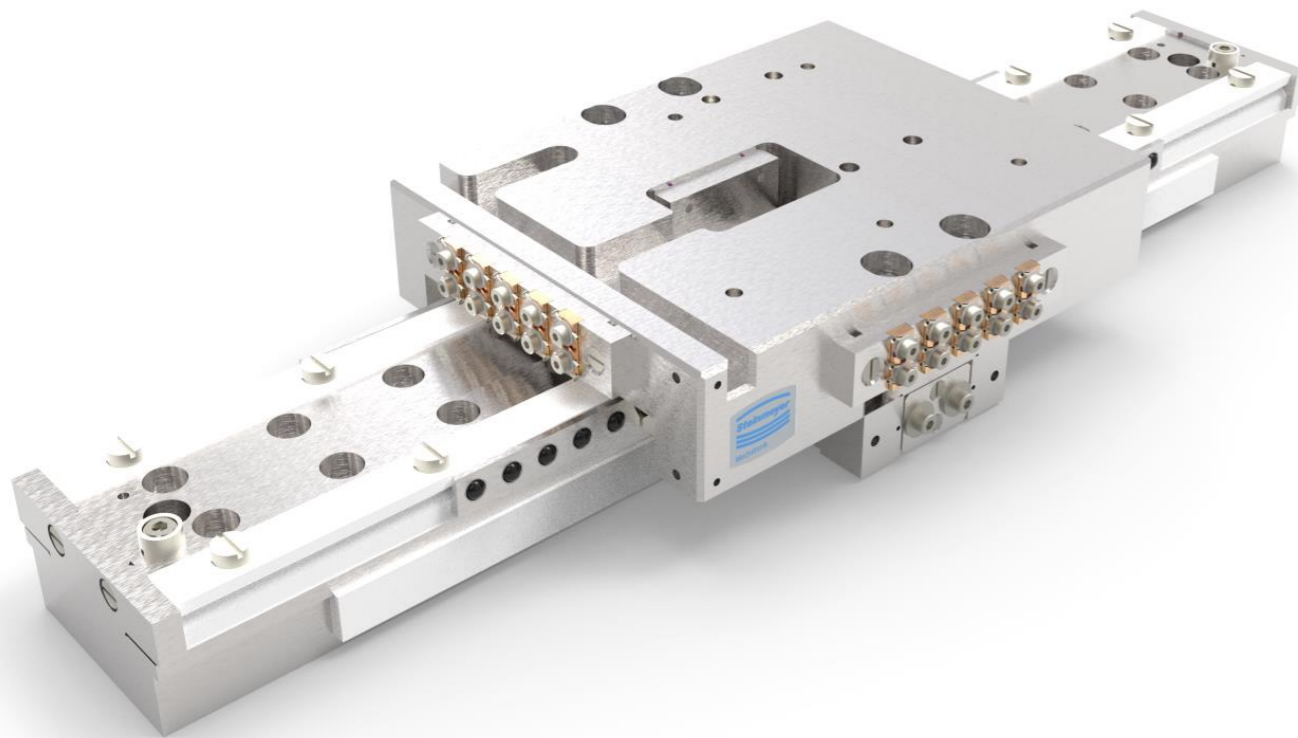

Application: scanning of samples

Benefit: Nanometer-positioning, also vertically

Features: positioning with extreme resolution and highest stiffness

Can be equipped with 2 (or 4) motors.

- Vacuum: all pressure ranges HV / UHV down to 10^{-11} mbar
- Magnetism: magnetic / low magnetic / magnet free
- Lubrication: liquid down to 10^{-8} mbar / dry lube down to 10^{-11} mbar
- max. bake-out temperature: 120°C

Technical Data

- Stroke: 100mm, 200mm, 300mm
- Repeatability: ± 20 nm
- Load: 4kg, 7kg, 10kg horizontally, 2kg, 4kg, 6kg vertically
- Velocity: 5mm/s

Components

- Motor: Piezo Motor
- Feedback: Linear 1nm...100nm
- Guide: Cross Roller Stainless Steel, Hybrid, optionally Ceramics
- Controller: Galil

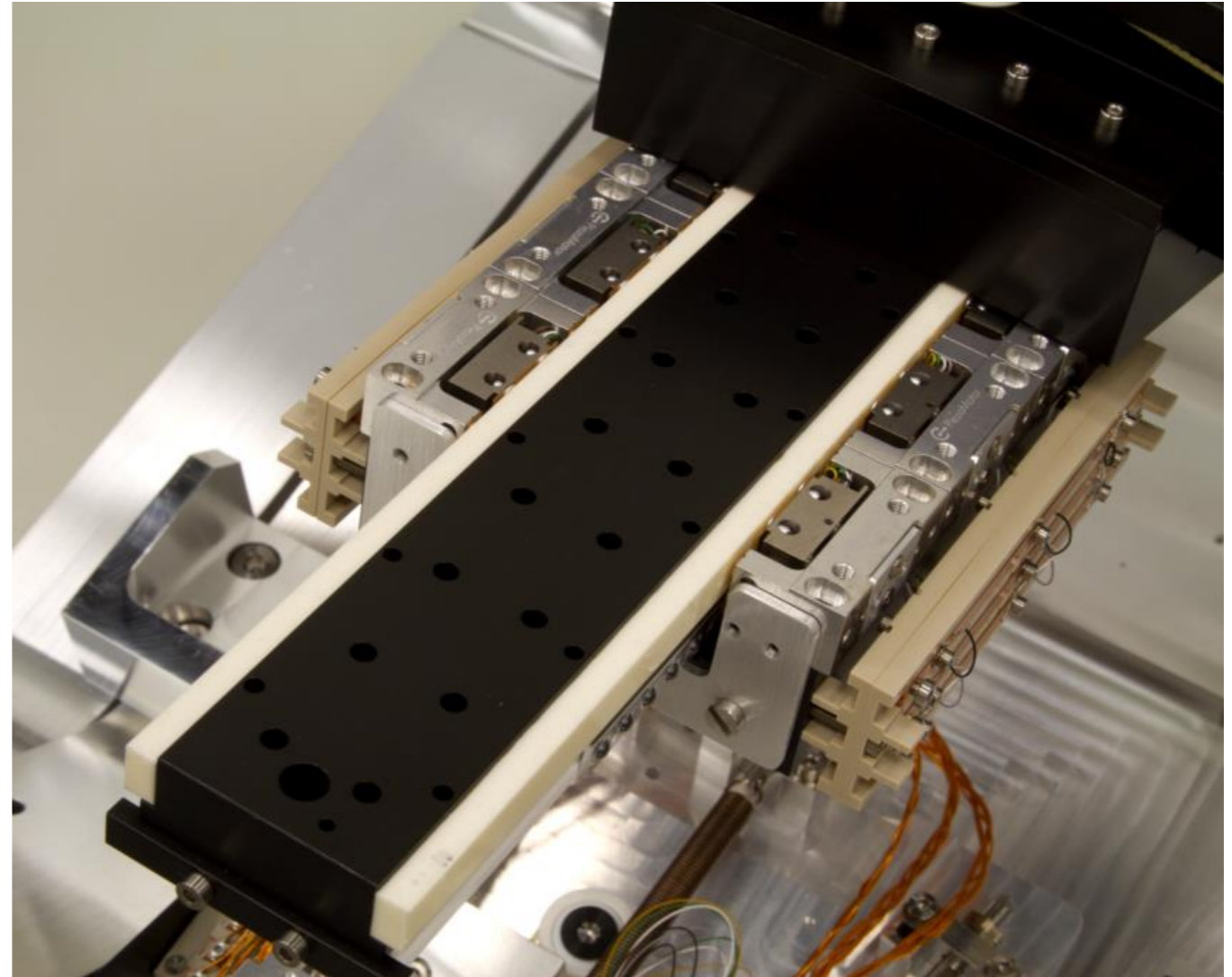
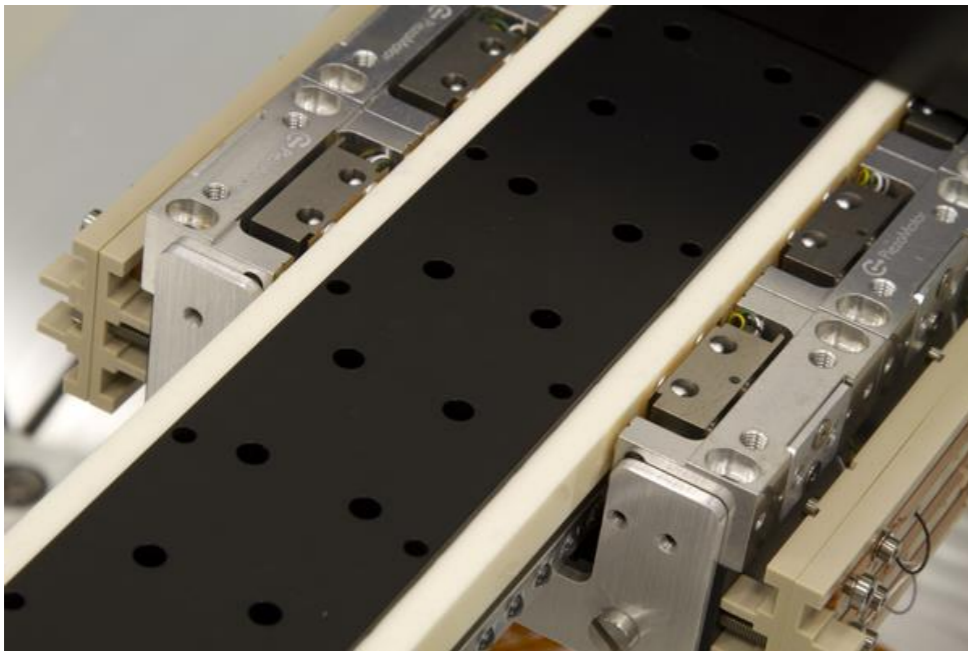
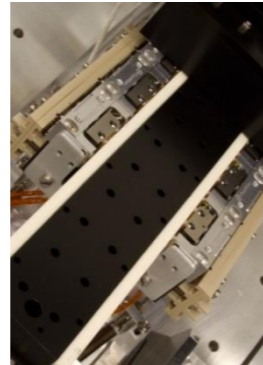
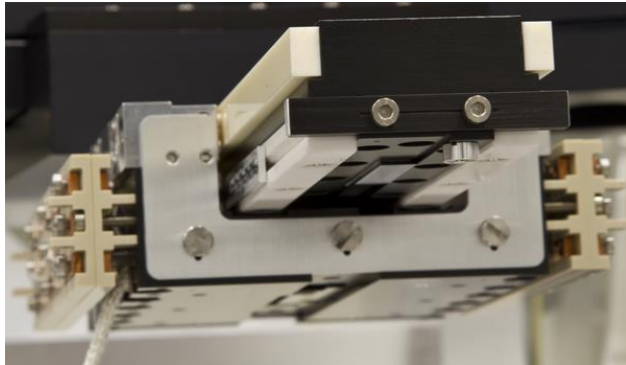

Vacuum Micro Stages

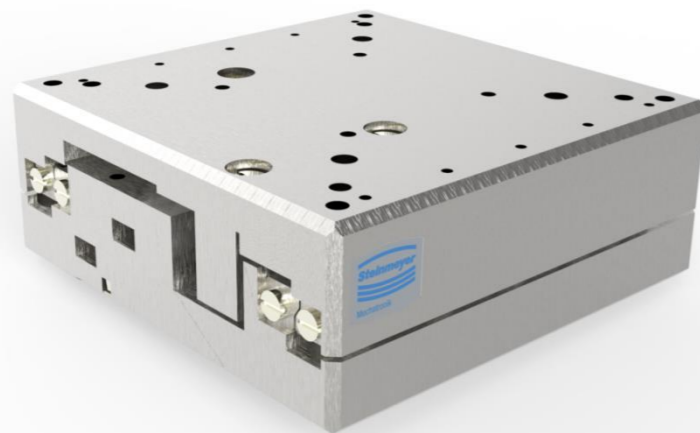

Application: multi purpose micro stage

Benefit: for high resolution scanning

Features: positioning with very high resolution

- Vacuum: all pressure ranges HV / UHV down to 10^{-11} mbar
- Magnetism: magnetic / low magnetic / magnet free
- Lubrication: liquid down to 10^{-8} mbar / dry lube down to 10^{-11} mbar
- max. bake-out temperature: 120°C

Technical Data

- Stroke: 10mm
- Repeatability: $\pm 0,1\mu\text{m}$
- Load: 0,9kg horizontally, 0,2kg vertically
- Velocity: 5mm/s

Components

- Motor: Piezo Motor
- Feedback: Linear 5nm...100nm
- Guide: Cross Roller Stainless Steel, Hybrid, optionally Ceramics
- Controller: Galil



Version with one Motor



Version with two Motors

Application: multi purpose micro stage

Benefit: for high resolution scanning

Features: positioning with very high resolution

- Vacuum: all pressure ranges HV / UHV down to 10^{-11} mbar
- Magnetism: magnetic / low magnetic / magnet free
- Lubrication: liquid down to 10^{-8} mbar / dry lube down to 10^{-11} mbar
- max. bake-out temperature: 120°C

Technical Data

- Stroke: 20mm (two Motors), 50mm, 100mm
- Repeatability: $\pm 0,4\mu\text{m}$ NM, $\pm 0,1\mu\text{m}$ PM
- Load: : 5kg horizontal / 0,5kg verticaly, 1kg verticaly (2 motors)
- Velocity: 5mm/s PM or 50mm/s NM

Components

- Motor: Piezo Motor / Nanomotion
- Feedback: Linear 5nm...100nm
- Guide: Cross Roller Stainless Steel, Hybrid, optionally Ceramics
- Controller: Galil

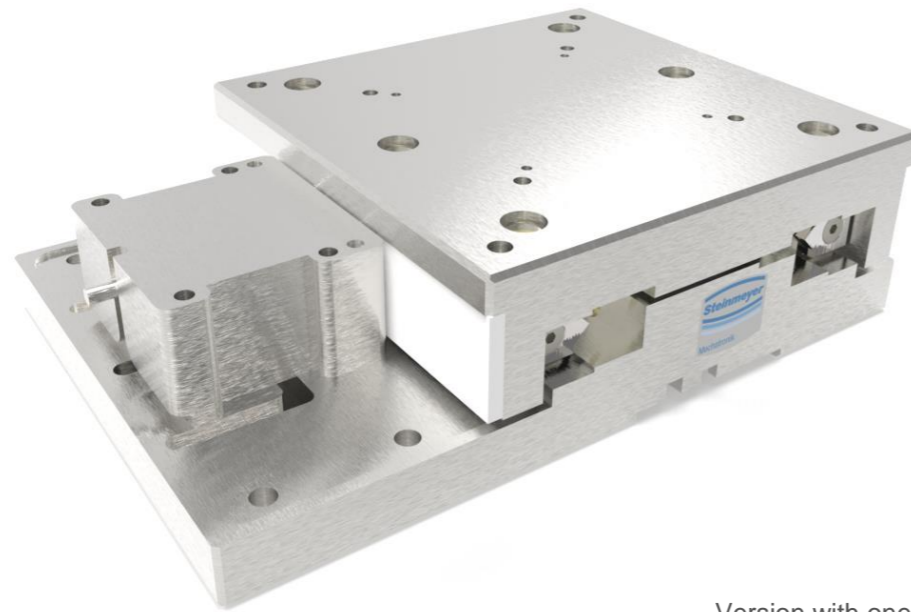

Version with one Motor

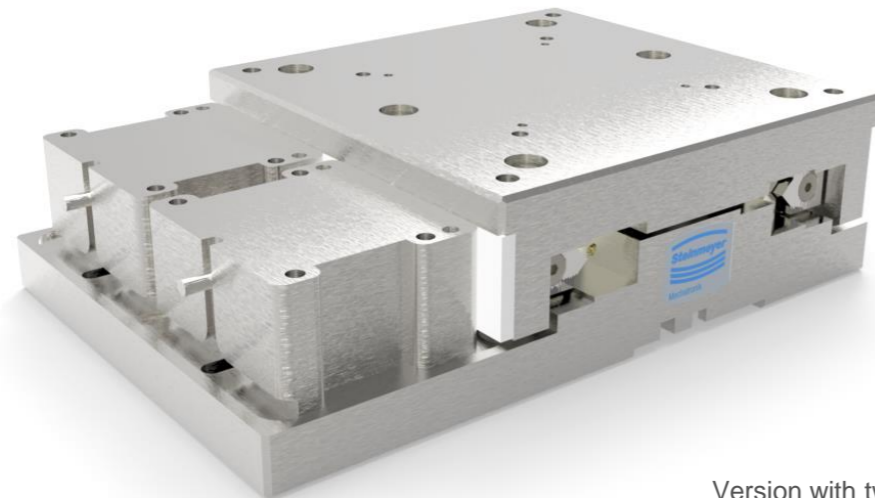

Version with two Motors

Application: multi purpose micro stage for vertical use

Benefit: for high resolution scanning

Features: positioning with very high resolution

- Vacuum: all pressure ranges HV / UHV down to 10^{-11} mbar
- Magnetism: magnetic / low magnetic / magnet free
- Lubrication: liquid down to 10^{-8} mbar / dry lube down to 10^{-11} mbar
- max. bake-out temperature: 120°C

Technical Data

- Stroke: 20mm (2 Motoren), 50mm, 100mm
- Repeatability: $\pm 0,4\mu\text{m}$ NM, $\pm 0,1\mu\text{m}$ PM
- Load: 10kg horizontally / 1,5kg vertically, 3kg vertically (2 motors)
- Velocity: 5mm/s PM, 50mm/s NM

Components

- Motor: Piezo Motor / Nanomotion
- Feedback: Linear 5nm...100nm
- Guide: Cross Roller Stainless Steel, Hybrid, optionally Ceramics
- Controller: Galil

Vacuum XY-Stages

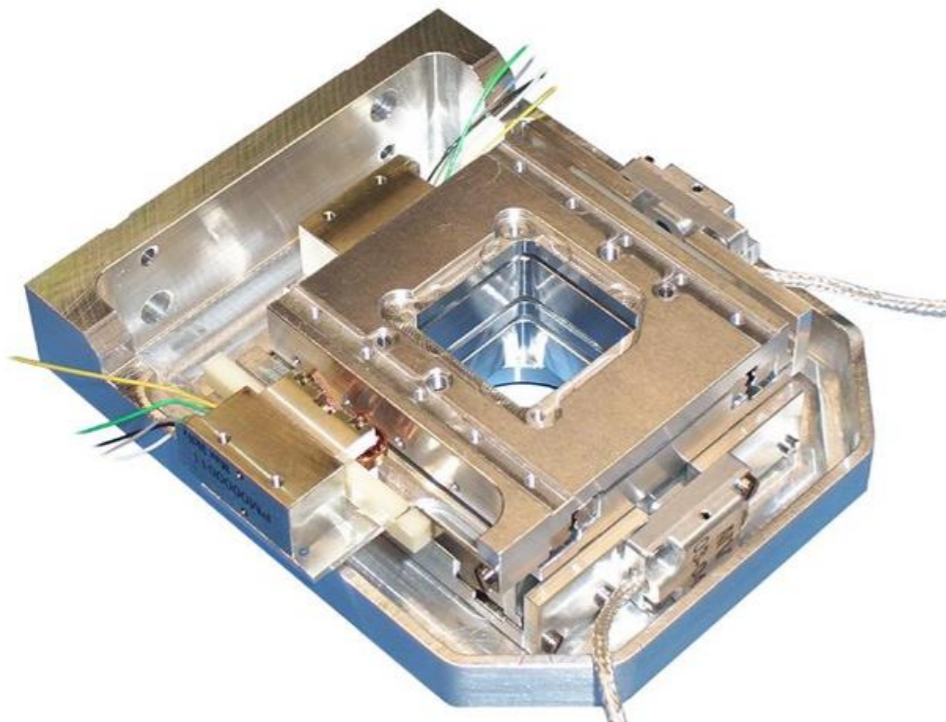

Application: sample stage

Benefit: high precision XY-stage

Features: serial product, very high resolution,
also available in titanium

- Vacuum: all pressure ranges HV / UHV down to 10^{-11} mbar
- Magnetism: magnetic / low magnetic / magnet free
- Lubrication: liquid down to 10^{-8} mbar / dry lube down to 10^{-11} mbar
- max. bake-out temperature: 120°C

Technical Data

- Stroke: 20mm x 20mm
- Repeatability: 50nm
- Load: 0,5kg horizontally
- Velocity: 5mm/s

Components

- Motor: Piezo Motor
- Feedback: Linear 5nm...100nm
- Guide: Cross Roller Stainless Steel, Hybrid, optionally Ceramics
- Controller: Galil



Steinmeyer
Mechatronik

XY-Stage KT105-50-NM/PM / KT180-100-NM/PM

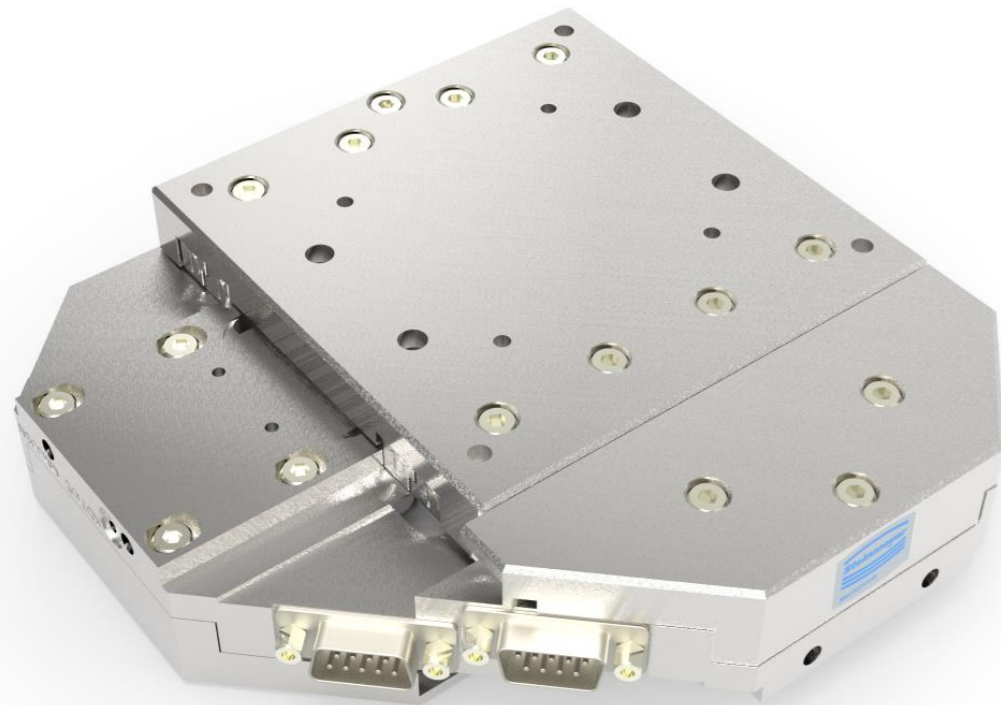

Application: vacuum-xy-stage

Benefit: fast and high resolution

Features: parameters for yaw and pitch three times better than the variant with aperture

- Vacuum: all pressure ranges HV / UHV down to 10^{-11} mbar
- Magnetism: magnetic / low magnetic / magnet free
- Lubrication: liquid lube down to 10^{-8} mbar / dry lube down to 10^{-11} mbar
- max. bake-out temperature: 120°C

Technical Data

- Stroke: 50mm, 100mm
- Repeatability: $\pm 0,4\mu\text{m}$ NM, $\pm 0,1\mu\text{m}$ PM
- Load: dry lube ca. 1kg, liquid lube ca. 5kg horizontally
- Velocity: 5mm/s PM or 100mm/s NM

Components

- Motor: Piezo Motor, Nanomotion
- Feedback: Linear 1nm...100nm
- Guide: Cross Roller Stainless Steel, Hybrid, optionally Ceramics
- Controller: Galil



Mechatronik

XY-Stage

KDT105-50-NM/PM / KDT180-100-NM/PM

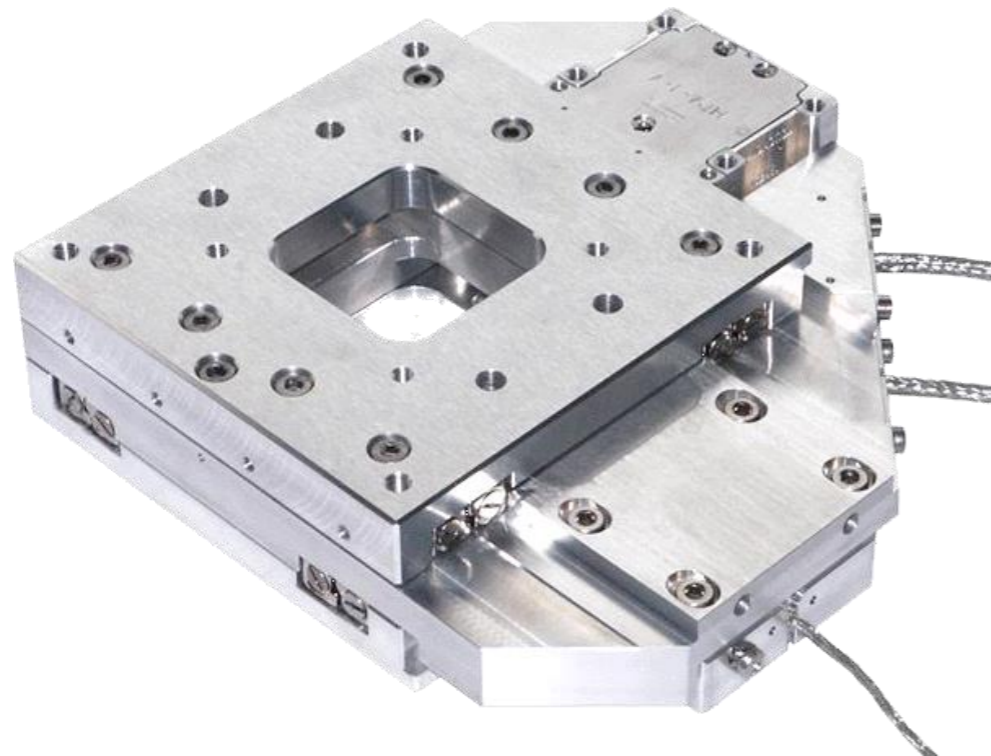

Application: vacuum-xy-stage

Benefit: fast and high resolution

Features: variant with aperture

- Vacuum: all pressure ranges HV / UHV down to 10^{-11} mbar
- Magnetism: magnetic / low magnetic / magnet free
- Lubrication: liquid down to 10^{-8} mbar / dry lube down to 10^{-11} mbar
- max. bake-out temperature: 120°C

Technical Data

- Stroke: 50mm
- Repeatability: $\pm 0,4\mu\text{m}$ NM, $\pm 0,1\mu\text{m}$ PM
- Load: dry lube ca. 1kg, liquid ca. 3kg horizontally
- Velocity: 5mm/s PM or 100mm/s NM

Components

- Motor: Piezo Motor, Nanomotion
- Feedback: Linear 1nm...100nm
- Guide: Cross Roller Stainless Steel, Hybrid, optionally Ceramics
- Controller: Galil

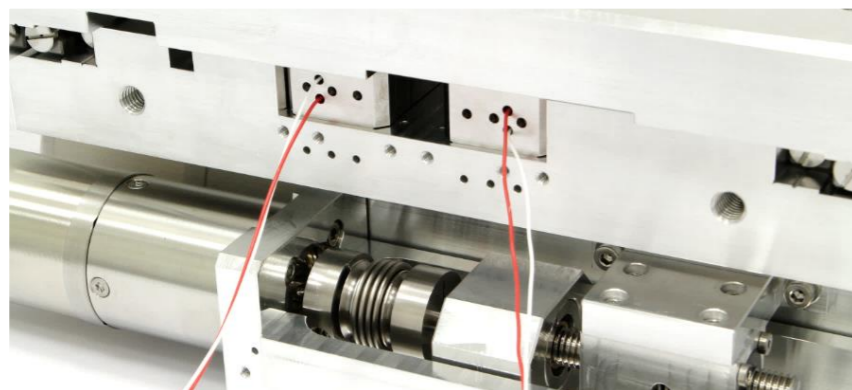

Application: transport stage, scanning stage for high loads

Benefit: high life time despite dry lube

Features: lead screw with dry lube or ball screw with liquid
piezo brakes for nm-stability

- Vacuum: all pressure ranges HV / UHV down to 10^{-11} mbar
- Magnetism: magnetic
- Lubrication: liquid down to 10^{-8} mbar / dry lube down to 10^{-11} mbar
- max. bake-out temperature: 120°C

Technical Data

- Stroke: 10mm, 50mm, 100mm
- Repeatability: $\pm 4\mu\text{m}$ SM, with Feedback $\pm 0,5\mu\text{m}$
- Load: 10kg horizontally
- Velocity: 5mm/s

Components

- Motor: Stepper Motor, (Ball Screw), Lead Screw
- Feedback: Open Loop or Linear Scale 100nm
- Guide: Cross Roller Stainless Steel, Hybrid
- Controller: FMC2, Galil

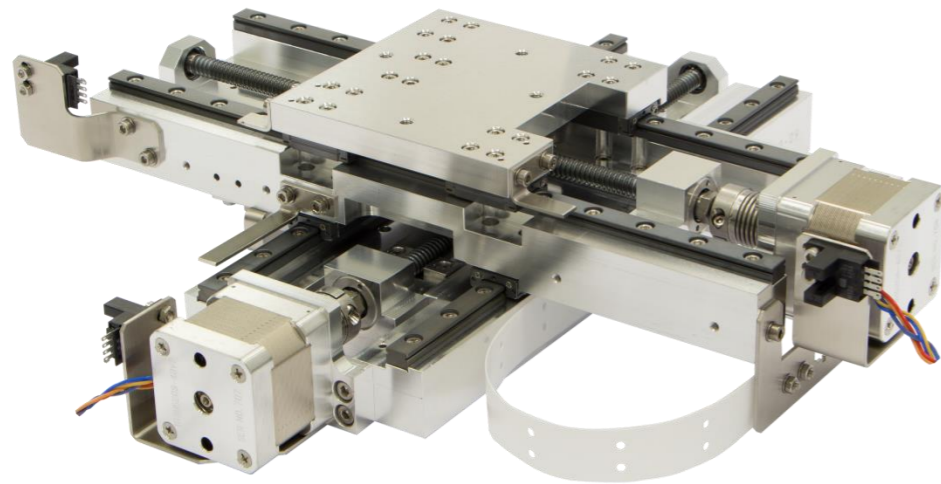

Application: compact scanning and transport stage

Benefit: small footprint

Features: compact height and large stroke

- Vacuum: all pressure ranges HV / UHV down to 10^{-8} mbar
- Magnetism: magnetic
- Lubrication: liquid
- max. bake-out temperature: 100°C

Technical Data

- Stroke: 100mm x 150mm (other lengths on request)
- Repeatability: $\pm 4\mu\text{m}$
- Load: 5kg horizontally
- Velocity: 20mm/s

Components

- Motor: Stepper Motor
- Feedback: none
- Guide: Stainless Steel-Mini Rail
- Controller: FMC, Galil

Vacuum Lifting Stages

Vacuum Lifting Stage HT160-SM

Application: vacuum lifting stage

Benefit: high stiffness and load

Features: wedge with ball screw spindle

- Vacuum: all pressure ranges HV / UHV down to 10^{-11} mbar
- Magnetism: magnetic
- Lubrication: liquid down to 10^{-8} mbar / dry lube down to 10^{-11} mbar
- max. bake-out temperature: 120°C

Technical Data

- Stroke: 16mm
- Repeatability: $\pm 4\mu\text{m}$ SM, with Feedback $\pm 1\mu\text{m}$
- Load: 5kg vertically
- Velocity: 8,3mm/s

Components

- Motor: Stepper Motor, (Ball Screw), Lead Screw
- Feedback: none or Linear
- Guide: Cross Roller Stainless Steel, Hybrid
- Controller: Galil

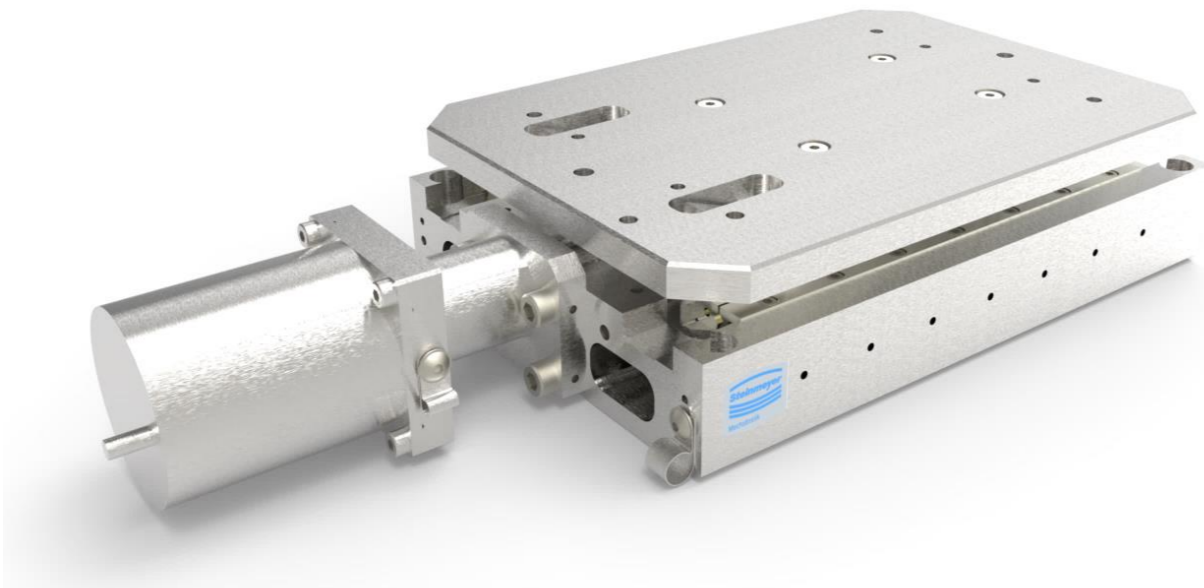

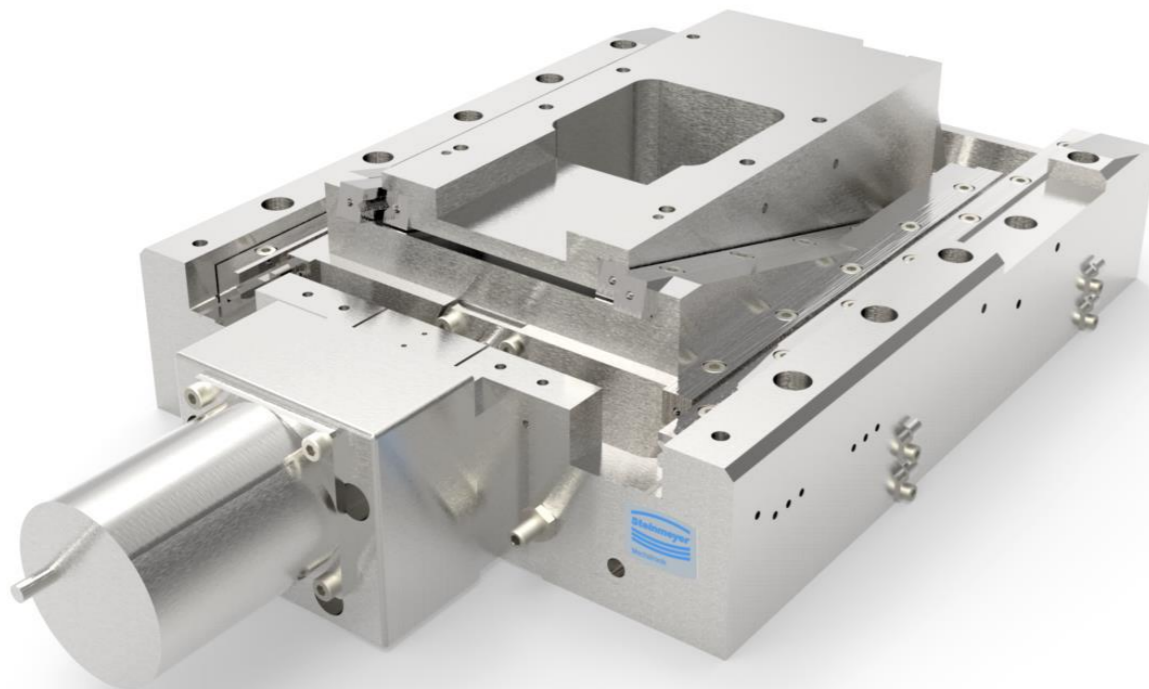

Application: vacuum lifting stage

Benefit: high stiffness and load, aperture

Features: wedge stage with aperture

- Vacuum: all pressure ranges HV / UHV down to 10^{-11} mbar
- Magnetism: magnetic
- Lubrication: liquid down to 10^{-8} mbar / dry lube down to 10^{-11} mbar
- max. bake-out temperature: 120°C

Technical Data

- Stroke: 16mm
- Repeatability: $\pm 4\mu\text{m}$ SM, with Feedback $\pm 1\mu\text{m}$
- Load: 10kg vertically
- Velocity: 8,3mm/s

Components

- Motor: Stepper Motor, (Ball Screw), Lead Screw
- Feedback: Open Loop or Linear Scale 100nm
- Guide: Cross Roller Stainless Steel, Hybrid
- Controller: Galil

Vacuum Lifting Stage HT240-SM

Application: vacuum lifting stage

Benefit: high stiffness and load

Features: wedge with ball screw spindle

- Vacuum: all pressure ranges HV / UHV down to 10^{-11} mbar
- Magnetism: magnetic
- Lubrication: liquid down to 10^{-8} mbar / dry lube down to 10^{-11} mbar
- max. bake-out temperature: 120°C

Technical Data

- Stroke: 25mm
- Repeatability: $\pm 4\mu\text{m}$ SM, with Feedback $\pm 1\mu\text{m}$
- Load: 40kg vertically
- Velocity: 8,3mm/s

Components

- Motor: Stepper Motor, (Ball Screw), Lead Screw
- Feedback: Open Loop or Linear Scale 100nm
- Guide: Cross Roller Stainless Steel, Hybrid
- Controller: Galil

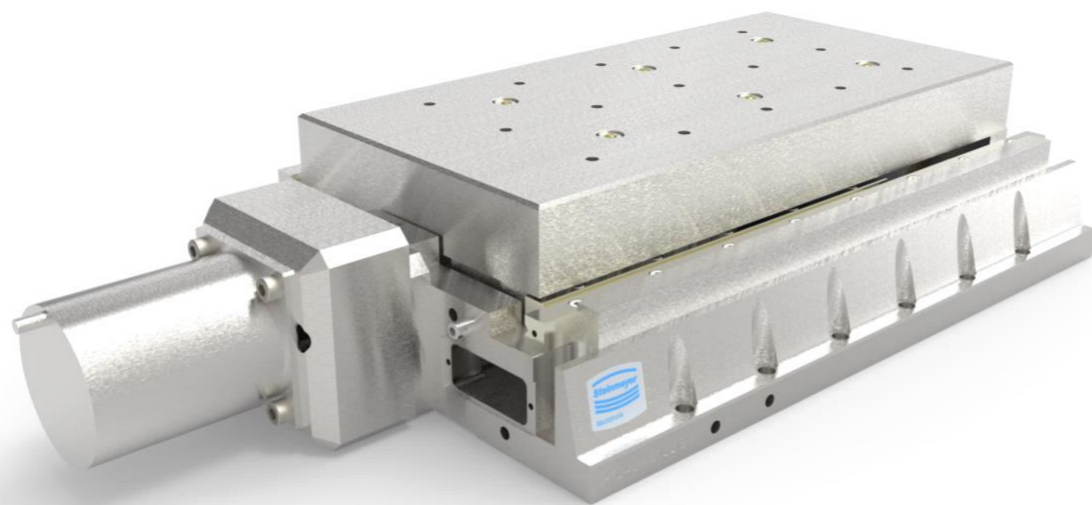

Vacuum Rotary Stages



Application: Vacuum-Rotary Stage

Benefit: for high resolution applications, high speed

Features: large aperture, compact height

- Vacuum: all pressure ranges HV / UHV down to 10^{-11} mbar
- Magnetism: magnetic / low magnetic
- Lubrication: liquid down to 10^{-8} mbar
- max. bake-out temperature: 100°C

Technical Data

- Rotation: n x 360deg
- Repeatability: uni $\pm 0,001$ deg
- Load: 0,5kg
- Velocity: 500deg/s

Components

- Motor: Nanomotion
- Feedback: 0,00005deg
- Guide: Stainless Steel
- Controller: Galil

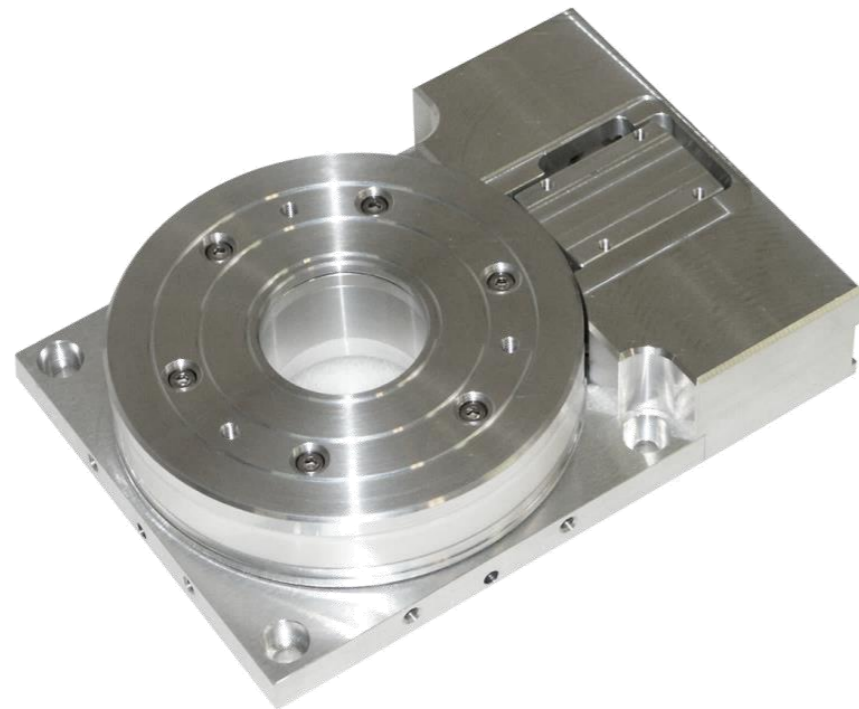

Application: Vacuum-Rotary Stage

Benefit: for high resolution applications, high speed

Features: large aperture, compact height

- Vacuum: all pressure ranges HV / UHV down to 10^{-11} mbar
- Magnetism: magnetic / low magnetic
- Lubrication: liquid down to 10^{-8} mbar
- max. bake-out temperature: 100°C

Technical Data

- Rotation: n x 360deg
- Repeatability: uni $\pm 0,0005$ deg
- Load: 1kg (up to 3kg with three Motors)
- Velocity: 360deg/s

Components

- Motor: Nanomotion
- Feedback: 0,00005deg
- Guide: Stainless Steel
- Controller: Galil

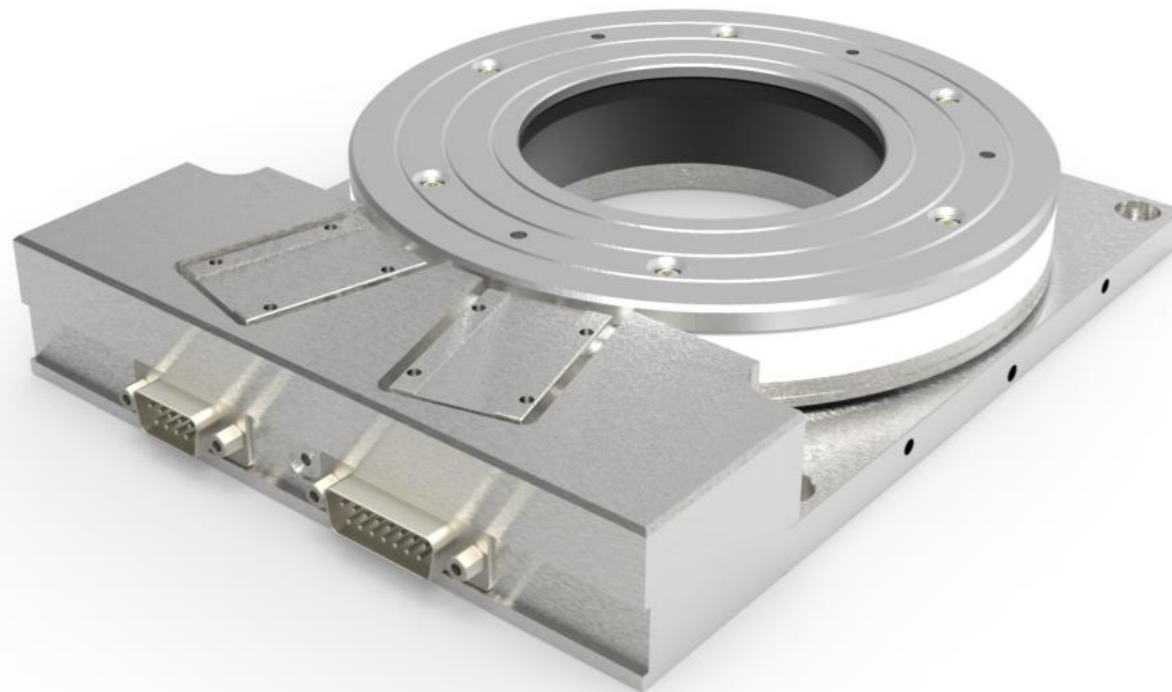

Application: Vacuum-Rotary Stage

Benefit: for high resolution applications, high speed

Features: large aperture, compact height

- Vacuum: all pressure ranges HV / UHV down to 10^{-11} mbar
- Magnetism: magnetic / low magnetic
- Lubrication: liquid down to 10^{-8} mbar
- max. bake-out temperature: 100°C

Technical Data

- Rotation: n x 360deg
- Repeatability: uni $\pm 0,0005$ deg
- Load: 5kg
- Velocity: 200deg/s

Components

- Motor: Nanomotion
- Feedback: 0,00005deg
- Guide: Stainless Steel
- Controller: Galil



Application: Vacuum-Rotary Stage

Benefit: for high resolution, high stability

Features: aperture, high load

- Vacuum: all pressure ranges HV / UHV down to 10^{-11} mbar
- Magnetism: magnetic / low magnetic / magnet free
- Lubrication: liquid down to 10^{-8} mbar / dry lube down to 10^{-11} mbar
- max. bake-out temperature: 120°C

Technical Data

- Rotation: n x 360deg or 370deg with hard stops
- Repeatability: uni $\pm 0,0002$ deg
- Load: 15kg
- Velocity: 90deg/s

Components

- Motor: Stepper Motor
- Feedback: Resolution 0,00002deg
- Bearing: Stainless Steel, Hybrid, optionally Ceramics
- Controller: Galil

Vacuum Manipulators



Mechatronik

Manipulator MP53-3-PM



Application: multi purpose manipulator

Benefit: for high resolution scanning

Features: positioning with very high resolution

- Vacuum: all pressure ranges HV / UHV down to 10^{-11} mbar
- Magnetism: magnetic / low magnetic / magnet free
- Lubrication: liquid down to 10^{-8} mbar / dry lube down to 10^{-11} mbar
- max. bake-out temperature: 120°C

Technical Data

- Stroke: 10mm
- Repeatability: uni $\pm 0,2\mu\text{m}$ and bi $\pm 0,3\mu\text{m}$
- Load: 0,2kg
- Velocity: 5mm/s

Components

- Motor: Piezo Motor / Nanomotion
- Feedback: Linear 5nm...100nm
- Guide: Cross Roller Stainless Steel, Hybrid, optionally Ceramics
- Controller: Galil

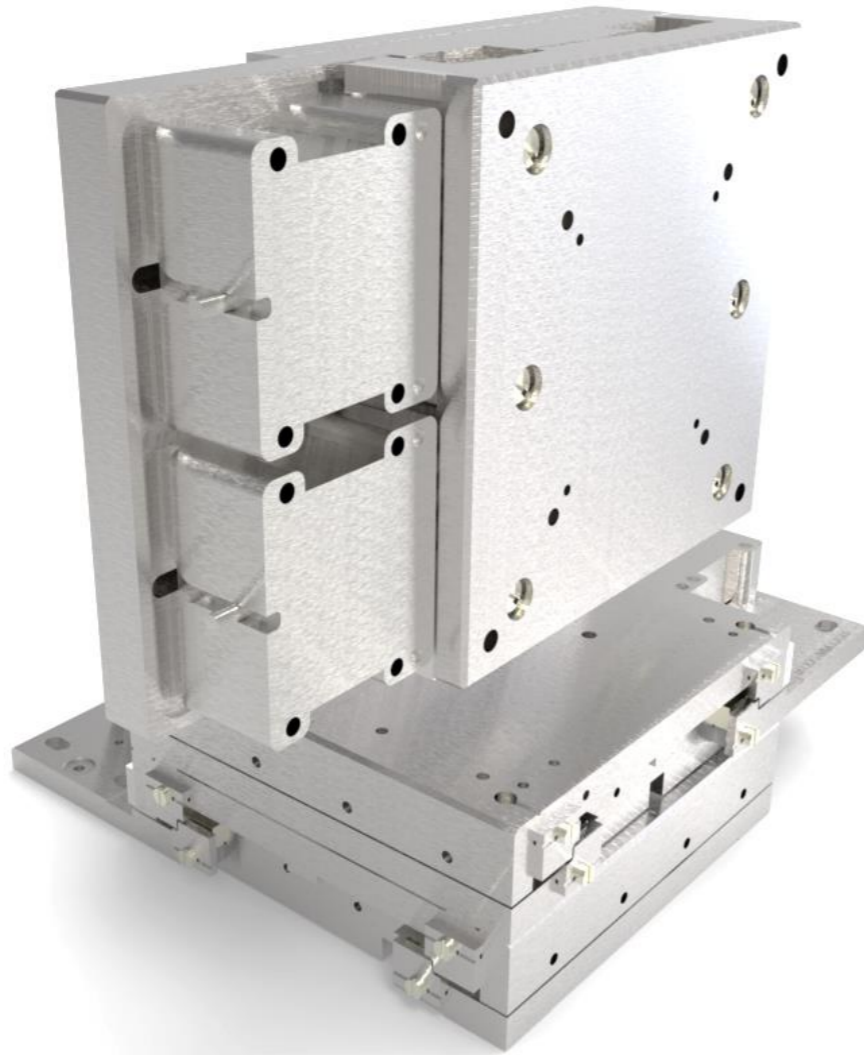

Application: multi purpose manipulator

Benefit: for high resolution scanning

Features: positioning with very high resolution

- Vacuum: all pressure ranges HV / UHV down to 10^{-11} mbar
- Magnetism: magnetic / low magnetic / magnet free
- Lubrication: liquid down to 10^{-8} mbar / dry lube down to 10^{-11} mbar
- max. bake-out temperature: 120°C

Technical Data

- Stroke: **XY** 50mm, **Z** 20 / 50mm
- Repeatability: uni $\pm 0,2\mu\text{m}$ and bi $\pm 0,3\mu\text{m}$
- Load: 5kg
- Velocity: 5mm/s PM or 100mm/s NM

Components

- Motor: Piezo Motor / Nanomotion
- Feedback: Linear 5nm...100nm
- Guide: Cross Roller Stainless Steel, Hybrid, optionally Ceramics
- Controller: Galil

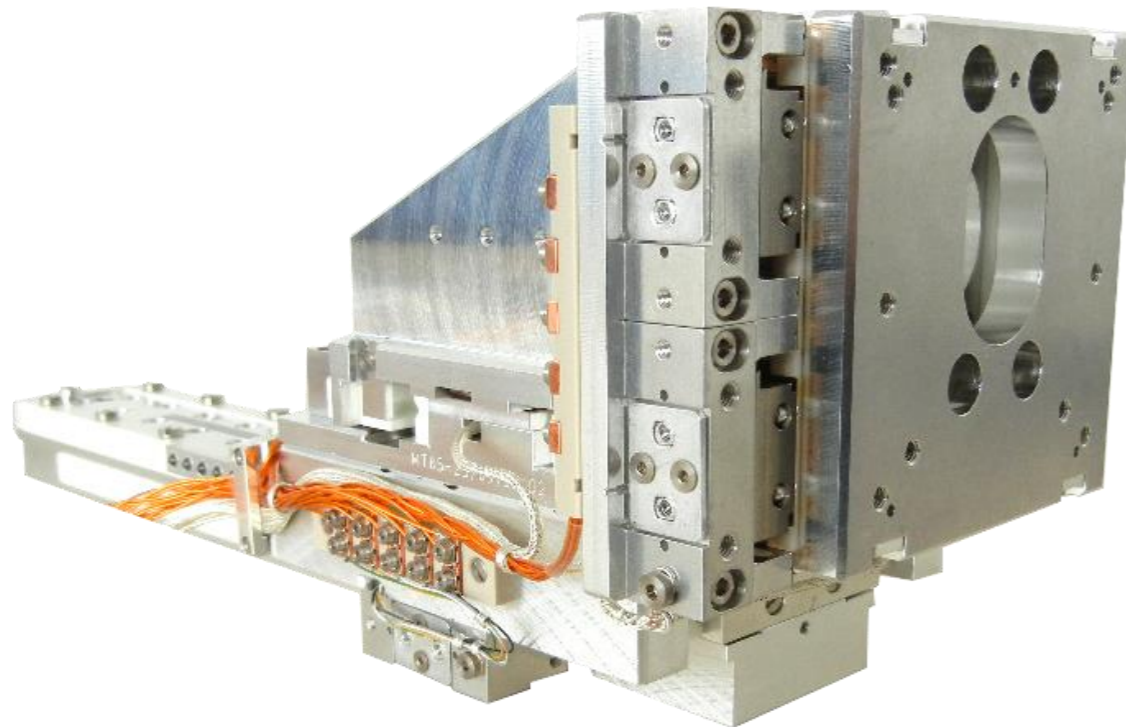

Application: multi purpose manipulator

Benefit: for high resolution scanning

Features: positioning with very high resolution

- Vacuum: all pressure ranges HV / UHV down to 10^{-11} mbar
- Magnetism: magnetic / low magnetic / magnet free
- Lubrication: liquid down to 10^{-8} mbar / dry lube down to 10^{-11} mbar
- max. bake-out temperature: 80°C

Technical Data

- Stroke: **X** 200mm / **ZY** 20mm
- Repeatability: uni \pm 20nm and bi \pm 30nm
- Load: 2kg
- Velocity: 5mm/s

Components

- Motor: Piezo Motor
- Feedback: Linear 1nm...100nm
- Guide: Cross Roller Stainless Steel, Hybrid, optionally Ceramics
- Controller: Galil

3-Axis-Manipulator of three LT300

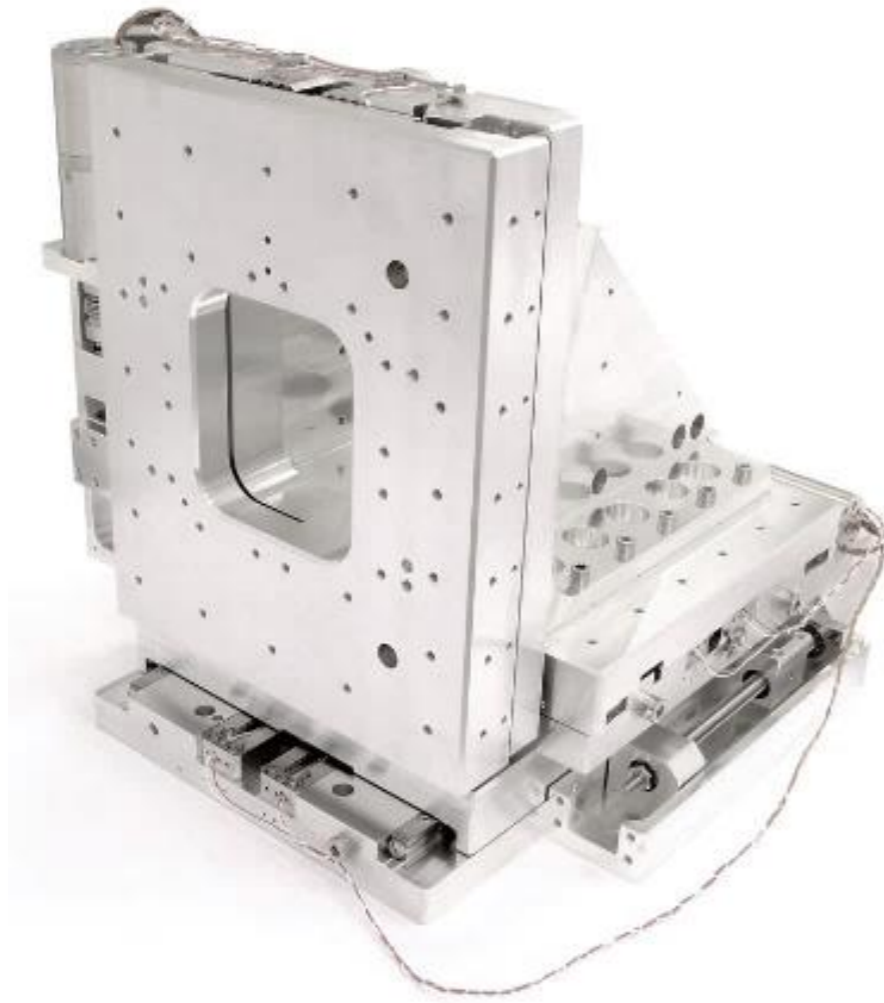

Application: HV-3-axis positioning system

Benefit: extremely stable upon reaching position,
dry lube

Features: stabilization with piezo brake

- Vacuum: all pressure ranges HV / UHV down to 10^{-11} mbar
- Magnetism: magnetic
- Lubrication: liquid down to 10^{-8} mbar / dry lube down to 10^{-11} mbar
- max. bake-out temperature: 120°C

Technical Data

- Stroke: 10...100mm x 10..100mm x 10..100mm
- Repeatability: $\pm 4\mu\text{m}$ SM, with Feedback $\pm 0,5\mu\text{m}$
- Load: 2...5kg
- Velocity: 5mm/s

Components

- Motor: Stepper Motor, (Ball Screw), Lead Screw
- Feedback: Open Loop or Linear Scale 1nm...100nm
- Guide: Cross Roller Stainless Steel, Hybrid
- Controller: FMC, Galil



Application: HV-2-axis positioning system

Benefit: extremely stable upon reaching position,
dry lube

Features: stabilization with piezo brake

- Vacuum: all pressure ranges HV / UHV down to 10^{-11} mbar
- Magnetism: magnetic
- Lubrication: liquid down to 10^{-8} mbar / dry lube down to 10^{-11} mbar
- max. bake-out temperature: 120°C

Technical Data

- Stroke: 7mm x 7mm or upon request
- Repeatability: $\pm 4\mu\text{m}$ SM, with Feedback $\pm 0,5\mu\text{m}$
- Load: 2kg
- Velocity: 5mm/s

Components

- Motor: Stepper Motor, (Ball Screw), Lead Screw
- Feedback: Open Loop or Linear Scale 100nm
- Guide: Cross Roller Stainless Steel, Hybrid
- Controller: FMC, Galil

3-Axis Manipulator of three LA95

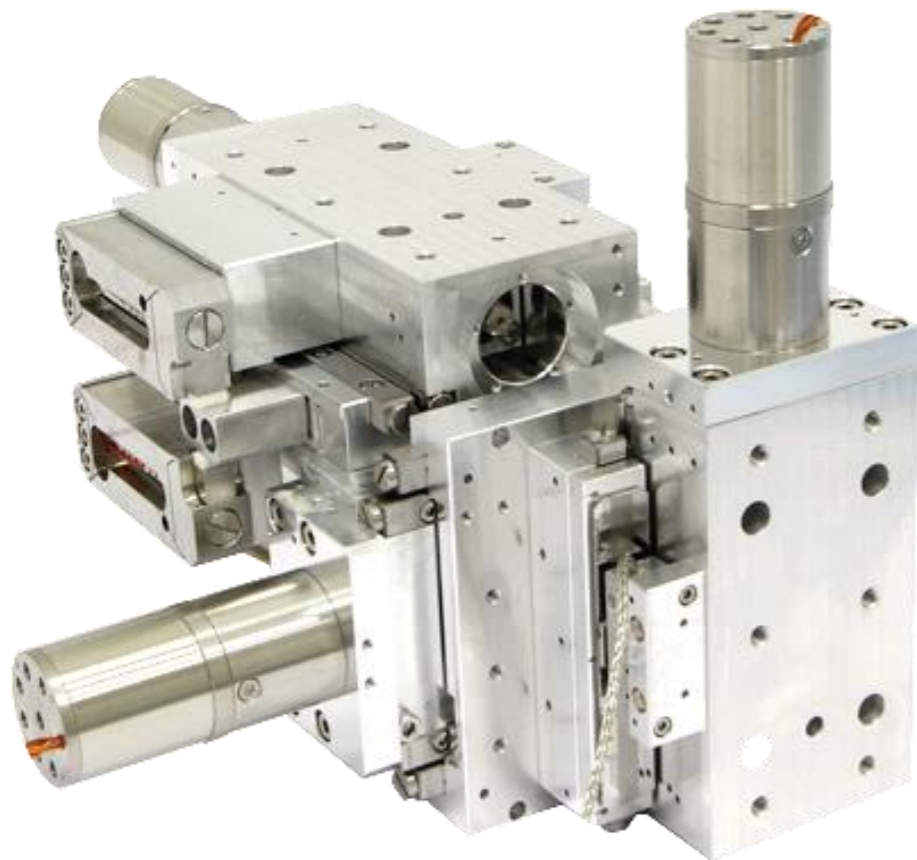

Application: HV-3-axis positioning system

Benefit: extremely stable upon reaching position,
dry lube

Features: stabilization with piezo brake

- Vacuum: all pressure ranges HV / UHV down to 10^{-11} mbar
- Magnetism: magnetic
- Lubrication: liquid down to 10^{-8} mbar / dry lube down to 10^{-11} mbar
- max. bake-out temperature: 120°C

Technical Data

- Stroke: 5mm x 20mm x 10mm or upon Request
- Repeatability: $\pm 4\mu\text{m}$ SM, with Feedback $\pm 0,5\mu\text{m}$
- Load: 2kg
- Velocity: 5mm/s

Components

- Motor: Stepper Motor, (Ball Screw), Lead Screw
- Feedback: Open Loop or Linear Scale 100nm
- Guide: Cross Roller Stainless Steel, Hybrid
- Controller: FMC, Galil

3-Axis Manipulator of three LA170

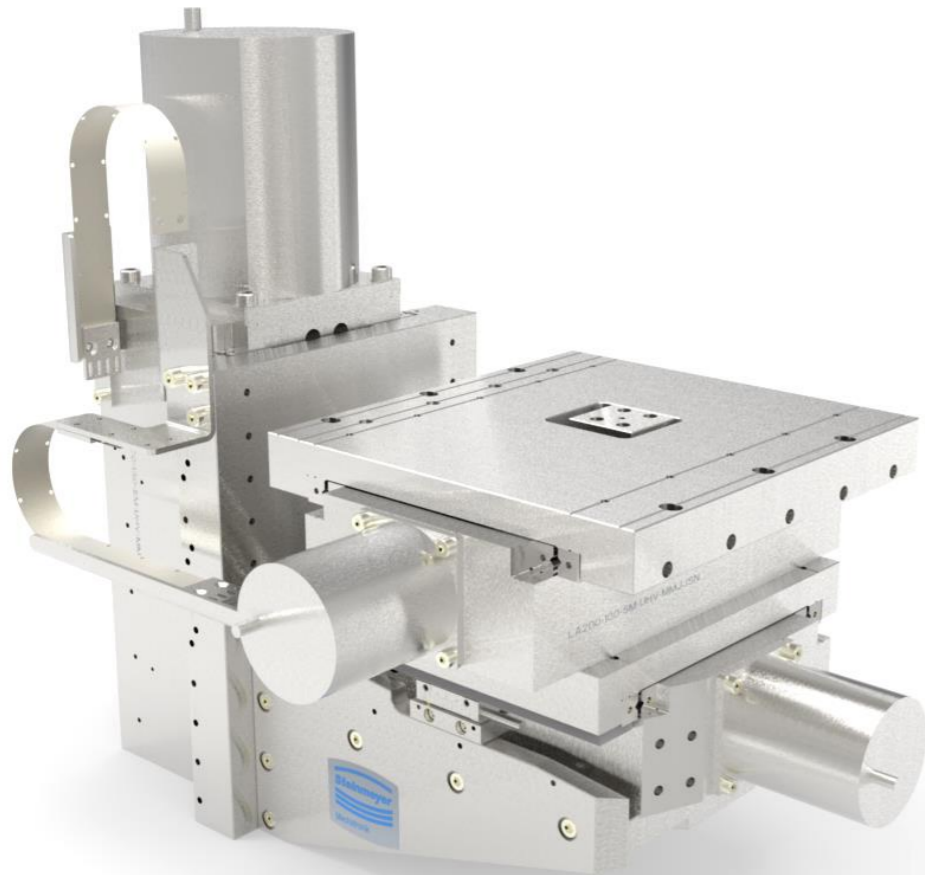

Application: HV-3-axis positioning system

Benefit: extremely stable upon reaching position,
dry lube

Features: stabilization with piezo brake, high load

- Vacuum: all pressure ranges HV / UHV down to 10^{-11} mbar
- Magnetism: magnetic
- Lubrication: liquid down to 10^{-8} mbar / dry lube down to 10^{-11} mbar
- max. bake-out temperature: 120°C

Technical Data

- Stroke: 10mm x 10mm x 10mm or upon Request
- Repeatability: $\pm 4\mu\text{m}$ SM, with Feedback $\pm 0,5\mu\text{m}$
- Load: 20kg
- Velocity: 5mm/s

Components

- Motor: Stepper Motor, (Ball Screw), Lead Screw
- Feedback: Open Loop or Linear Scale 100nm
- Guide: Cross Roller Stainless Steel, Hybrid
- Controller: FMC, Galil

3-Axis Manipulator of LA80 and two LA95

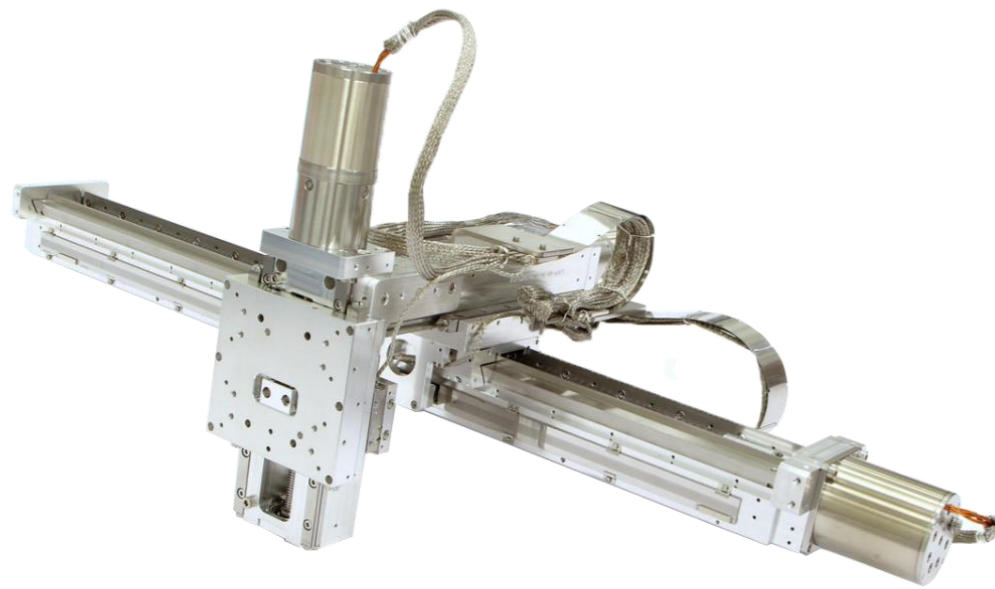

Application: HV-3-axis positioning system

Benefit: extremely stable upon reaching position,
dry lube

Features: high speed transfer axes

- Vacuum: all pressure ranges HV / UHV down to 10^{-11} mbar
- Magnetism: magnetic
- Lubrication: liquid down to 10^{-8} mbar / dry lube down to 10^{-11} mbar
- max. bake-out temperature: 120°C

Technical Data

- Stroke: 200mm x 20mm x 20mm
- Repeatability: $\pm 4\mu\text{m}$ SM, with Feedback $\pm 0,5\mu\text{m}$
- Load: 2kg
- Velocity: 5mm/s respectively 50mm/s

Components

- Motor: Stepper Motor, (Ball Screw), Lead Screw
- Feedback: Open Loop or Linear Scale 100nm
- Guide: Cross Roller Hybrid respectively recirculating Ball Guides
- Controller: Galil

Examples of Vacuum Systems

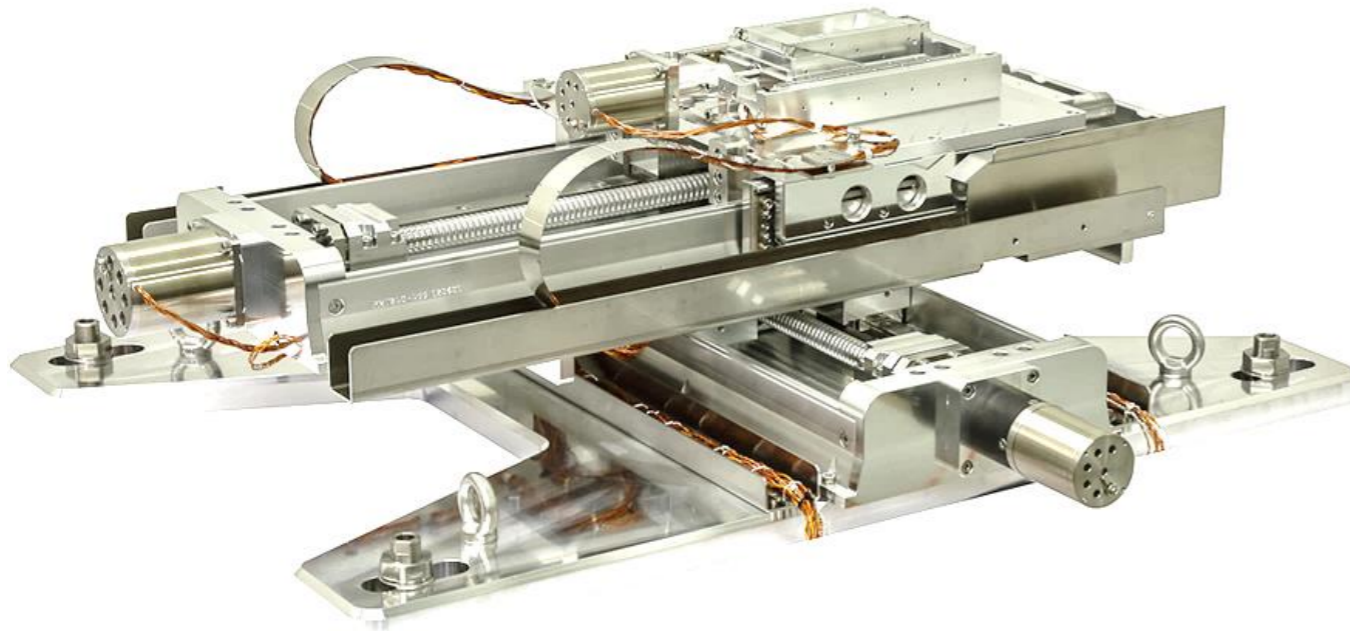

Application: investigation of mineral samples

Stages: X PLT240-SM, Y PLT240-SM, Z HT160-SM

Features: positioning of high loads in vacuum

- Vacuum: 10^{-6} mbar
- Magnetism: magnetic
- Lubrication: liquid
- max. bake-out temperature: 80°C

Technical Data

- Stroke: 200mm x 200mm x 16mm
- Repeatability: $\pm 4\mu\text{m}$
- Load: 20kg

Components

- Motor: Stepper Motor, Ball Screw
- Feedback: none
- Guide: Cross Roller Hybrid, Stainless Steel Mini Rail
- Controller: Galil

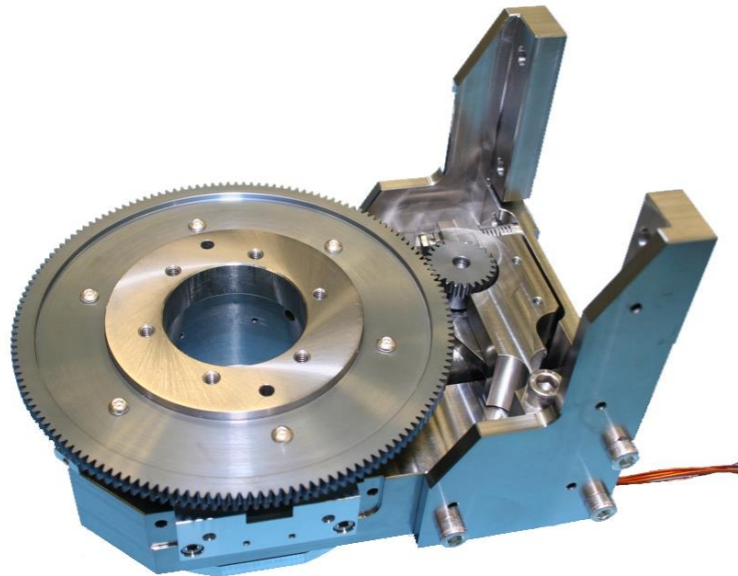
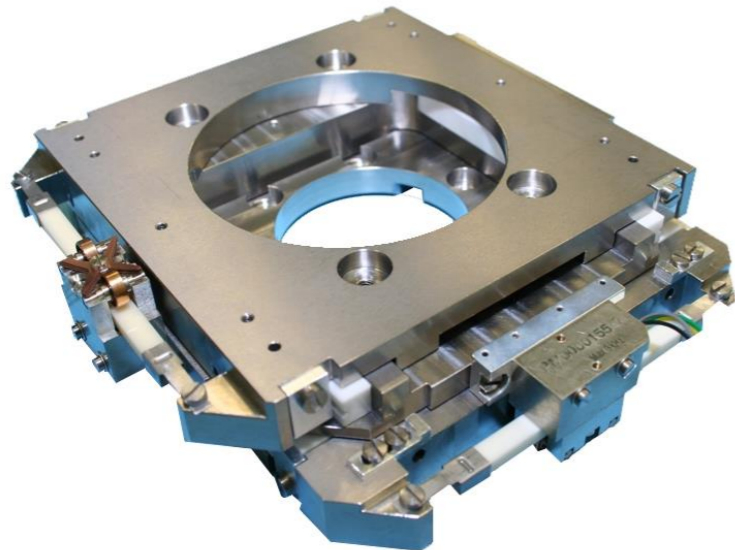

Application: sample translation and rotation

Stages: custom-KDT, custom-DT

Features: XY-Stages from titanium

- Vacuum: 10^{-11} mbar
- Magnetism: center components completely non-magnetic
- Lubrication: none
- max. bake-out temperature: 120°C

Technical Data

- Stroke: 20mm x 20mm x 50mm and Rotation
- Repeatability: $\pm 0,1\mu\text{m}$
- Load: 0,2kg

Components

- Motor: Piezo Motor, Stepper Motor
- Feedback: Linear 1nm
- Guide: Cross Roller and Bearing Ceramics, Stainless Steel Mini Rail
- Controller: Galil

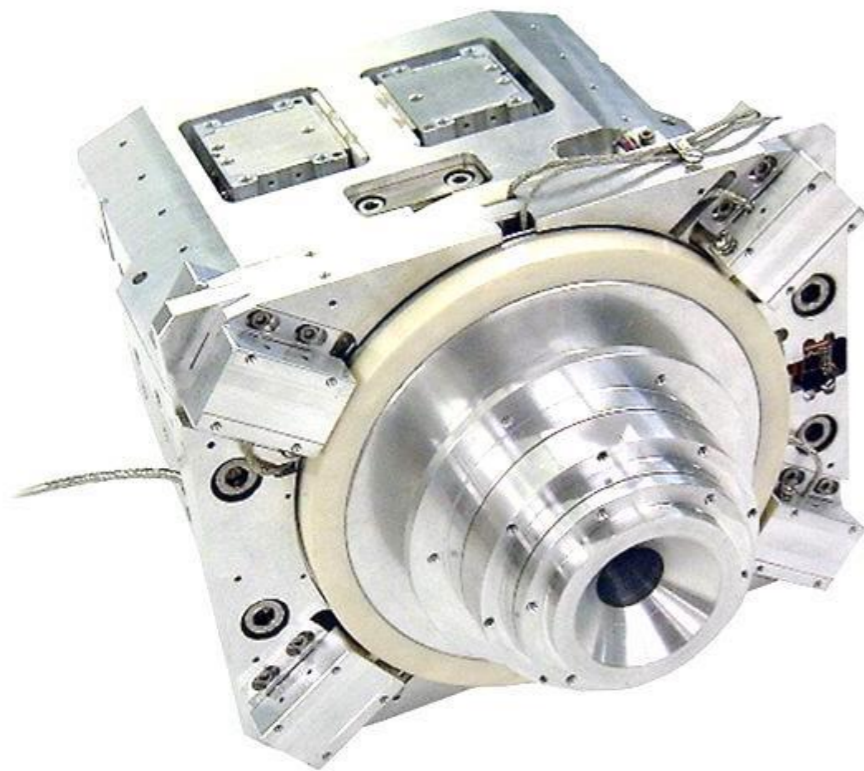

Application: machining with ion-beam

Stages: custom DT, custom DT,
custom linear stage

Features: two co-axial rotary stages with common linear

- Vacuum: 10^{-8} mbar
- Magnetism: non-magnetic
- Lubrication: minimal liquid
- max. bake-out temperature: 120°C

Technical Data

- Stroke: 50mm, Rotation, Rotation
- Repeatability: $\pm 0,1\mu\text{m}$
- Load: 0,25kg

Components

- Motor: Nanomotion
- Feedback: Angle, Linear 5nm
- Guide: Bearing Ceramics
- Controller: Galil

4+1-Axis Camera Manipulator

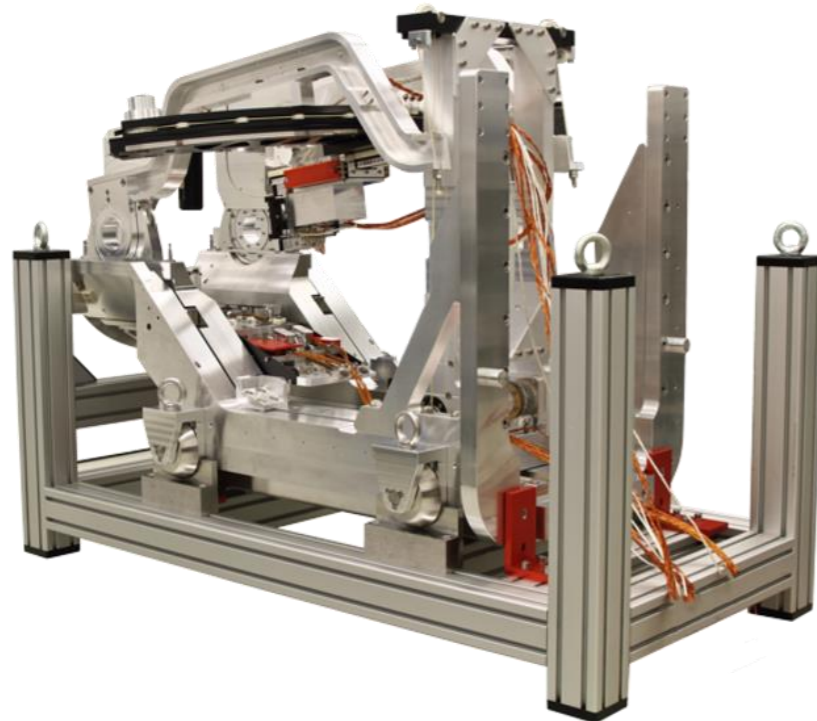
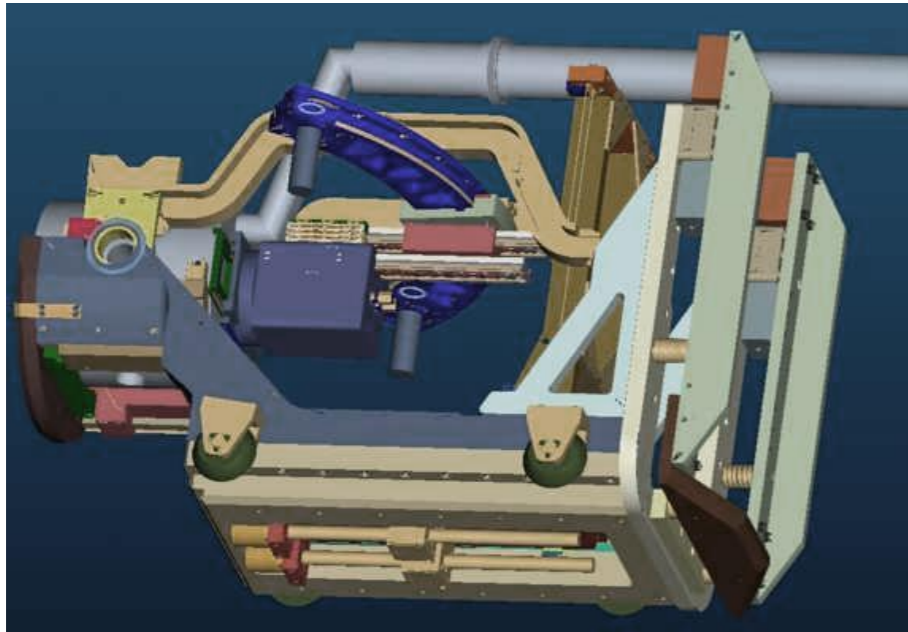

Application: 3D motion of an X-Ray camera

Stages: custom swivel horizontally
 custom swivel vertically
 custom linear stage A-Drive
 custom linear stage for filters
 global transfer with ball screw drive

Features: withstands strong magnetic scatter field in center of manipulator

- Vacuum: 10^{-8} mbar
- Magnetism: nonmagnetic in center
- Lubrication: dry lube, minimal liquid
- max. bake-out temperature: 80°C

Technical Data

- Stroke: ± 30 mm, ± 40 mm, 300mm, 100mm, 350mm
- Repeatability: $\pm 1\mu$ m
- Load: 8kg (120 kg for global transfer)

Components

- Motor: Piezo Motor, Stepper Motor, Rope, Worm, Ball Screw
- Feedback: Linear 100nm
- Guide: Bearing Ceramics
- Controller: Galil

6-Achs Sample Manipulator (RICS-Experiment)

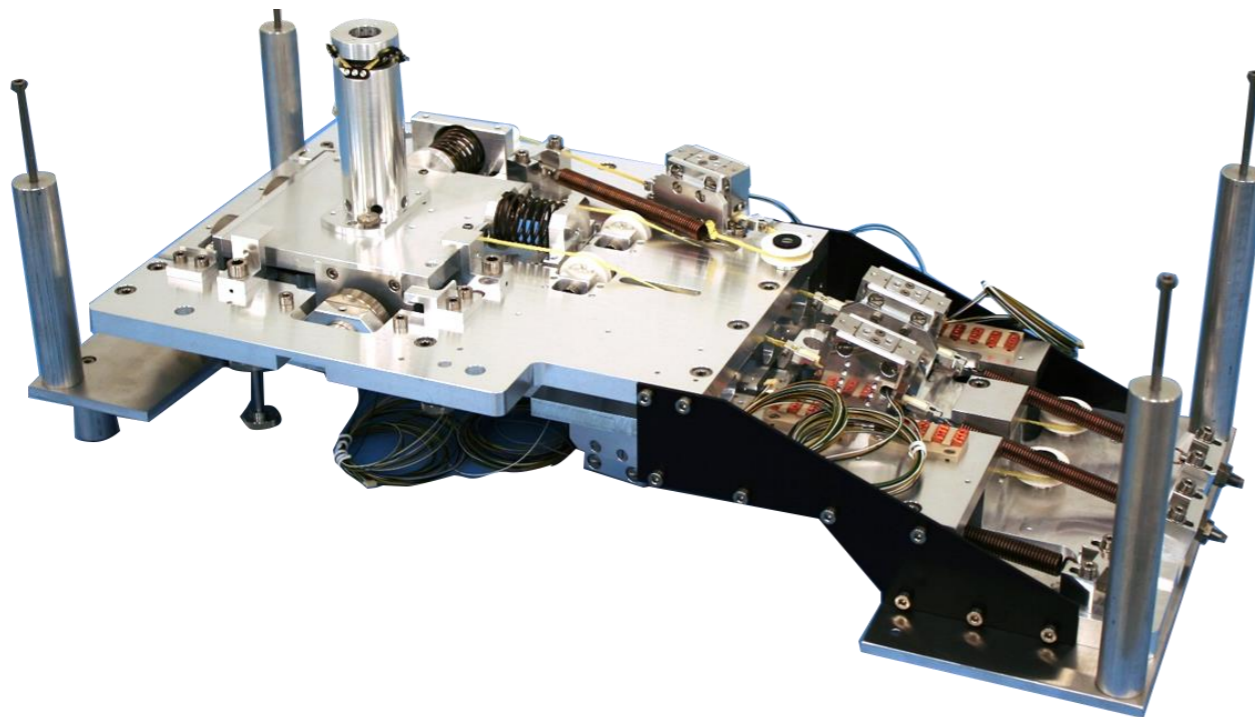

Application: μm and nm manipulation of samples

Stages: custom design of cartesian 6 dof manipulator

Features: ropes in vacuum, magnet free, capacitive sensors

- Vacuum: 10^{-8}mbar
- Magnetism: non-magnetic
- Lubrication: dry lube
- max. bake-out temperature: 80°C

Technical Data

- Stroke: translation $\text{XYZ} \pm 3\text{mm}$, rotational $\text{XYZ} \pm 1^{\circ}$
- Repeatability: $\pm 0,05\mu\text{m}$
- Load: $0,05\text{kg}$

Components

- Motor: Piezo Motor, Ropes
- Feedback: $0,1\text{nm}$ capacitive
- Guide: Ropes
- Controller: Galil

6-Achs Sample Manipulator (RICS-Experiment)

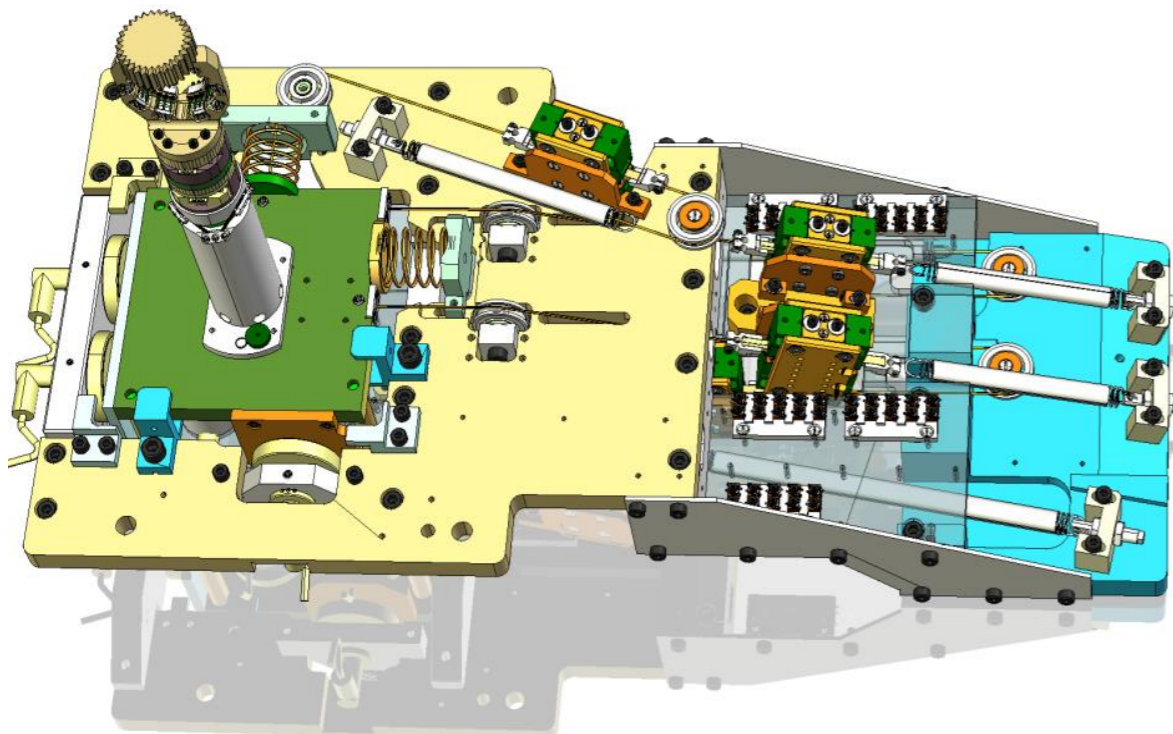

Sample Manipulator from Above

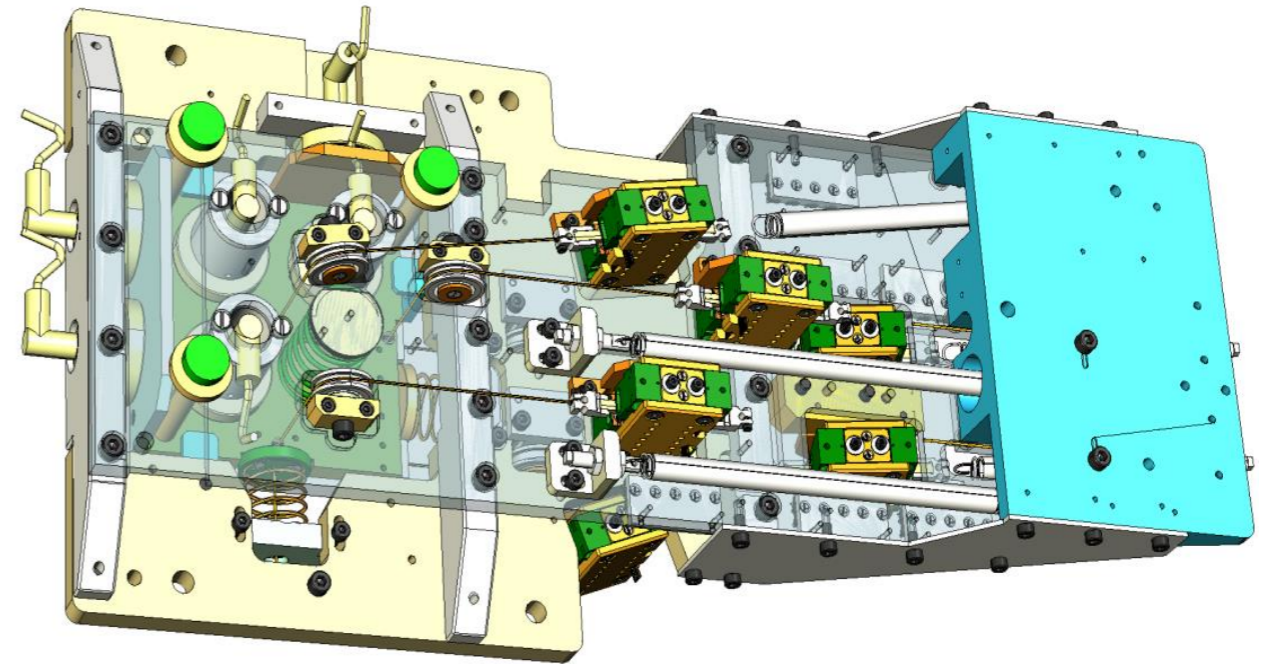

Sample Manipulator from Below



Application: adjusting position in a coating process

Stages: LPT60-SM, LPT60-SM, custom manual drive

Features: based on HV-versions of catalogue stages

- Vacuum: 10^{-6} mbar
- Magnetism: magnetic
- Lubrication: liquid
- max. bake-out temperature: 80°C

Technical Data

- Stroke: 100mm, 100mm, 150mm
- Repeatability: $\pm 4\mu\text{m}$
- Load: 5kg

Components

- Motor: Stepper Motor, Ball Screw
- Feedback: none
- Guide: Mini Rail Stainless Steel
- Controller: Galil

4 Axis Sample Manipulator

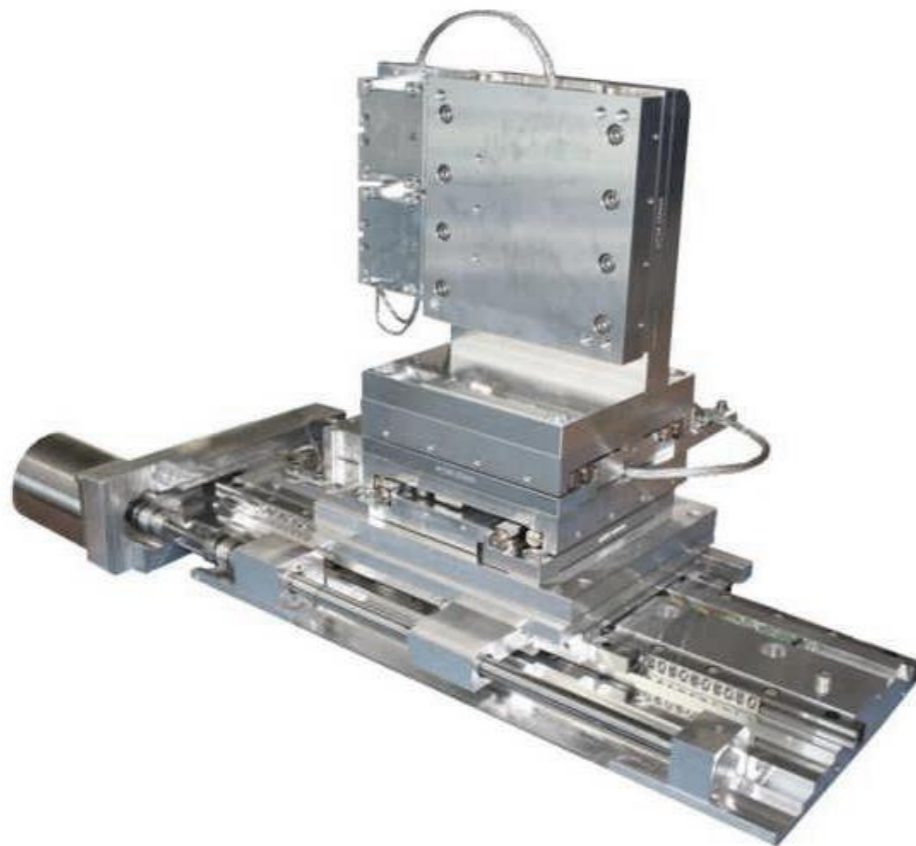

Application: sample translation

Stages: PMT160-SM, MT105-NM, MT105-NM, MT105-2NM

Features: coarse positioning with ball screw,
fine positioning with Nanomotion

- Vacuum: 10^{-8} mbar
- Magnetism: magnetic
- Lubrication: liquid
- max. bake-out temperature: 100°C

Technical Data

- Stroke: 100mm and 50mm x 50mm x 20mm
- Repeatability: $\pm 0,1\mu\text{m}$
- Load: 0,25kg

Components

- Motor: Nanomotion, Stepper Motor, Ball Screw
- Feedback: none, Linear 5nm
- Guide: Cross Roller
- Controller: Galil

Accessories and Features

Piezo Brake Enhances Stability

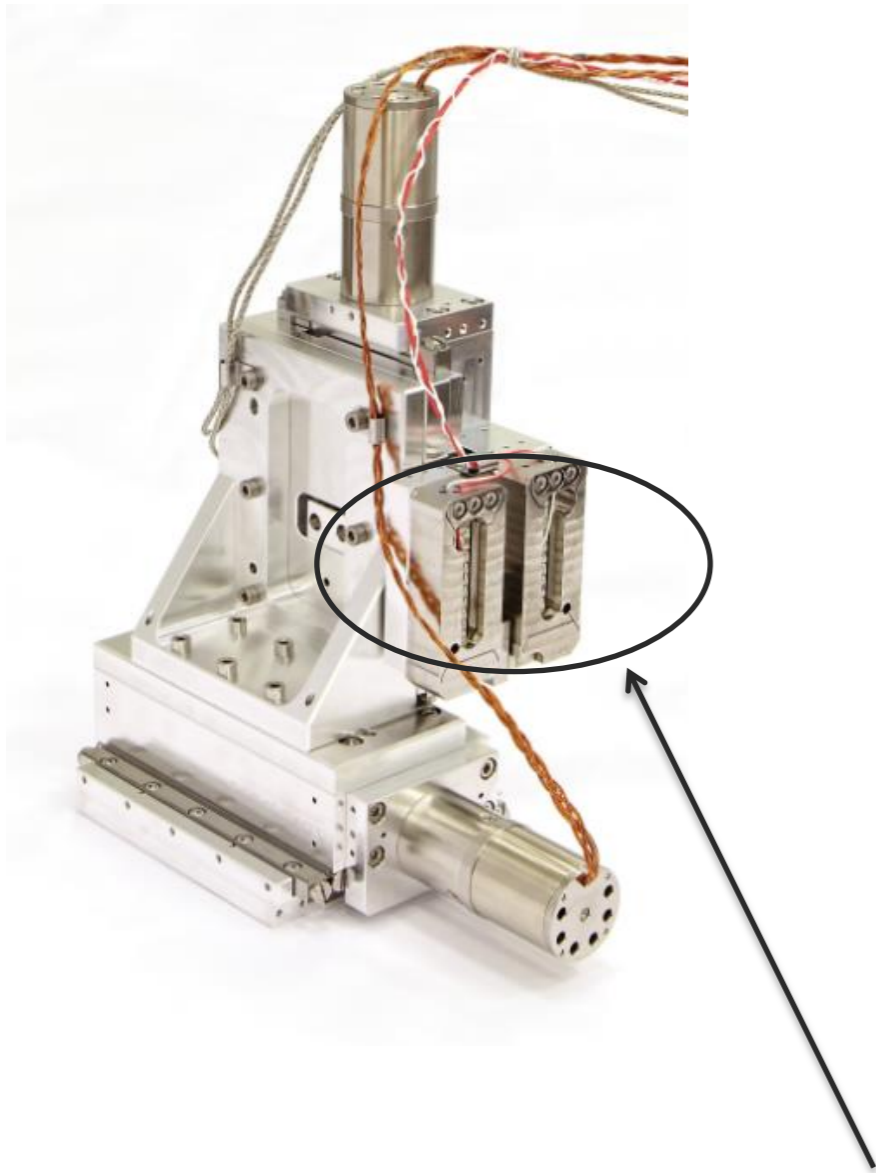

Upon reaching position the piezo brake engages and boosts stiffness. In result, light structures can be made extremely stiff.

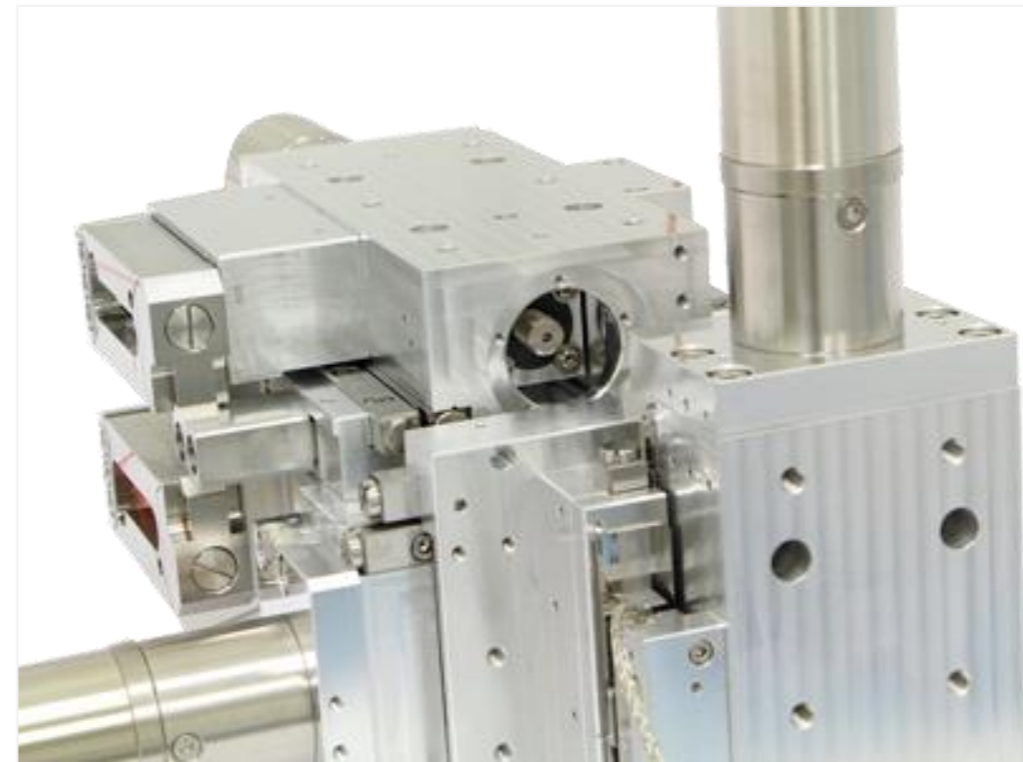
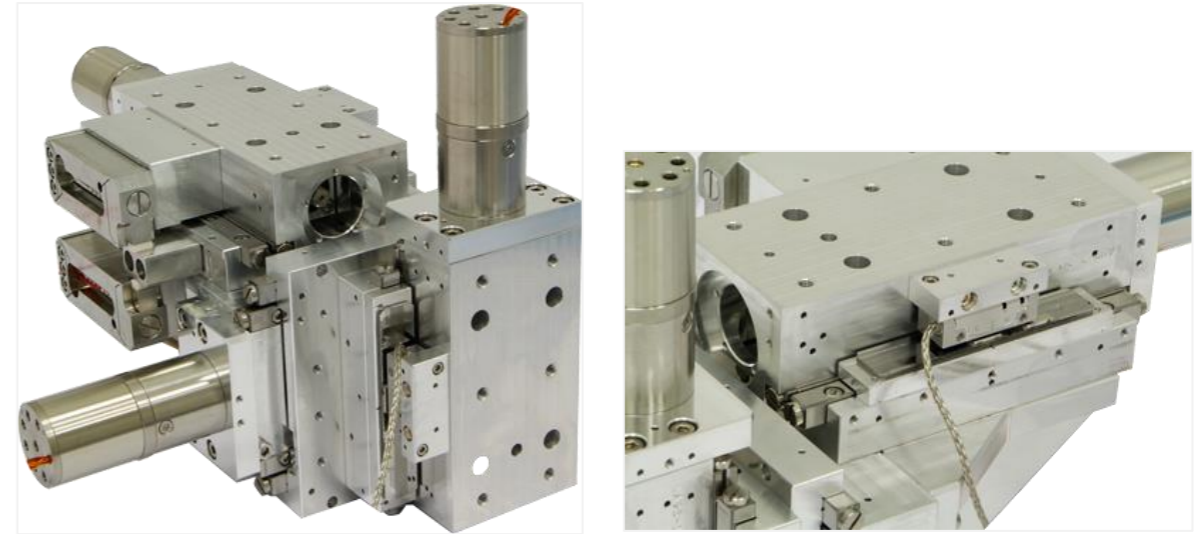



Mechatronik

Vacuum Stages Based on Atmospheric Standard Catalogue Stages



Most stages listed in our laboratory catalogue are available in HV-Vacuum preparation.

- Liquid lubrication for pressures down to 10^{-6} mbar
- Maximum bake-out temperature 80°C
- Fitted with Phytron stepper motors
- Stainless steel components (bearings, guides, ball screw)
- Kapton or PTFE cabling
- Kapton or Ceramic Sub-D plug
- Machined aluminum without anodization,
- Vacuum cleaned
- Venting holes, split washers or screws with bore
- Without covers
- Assembled in our clean room
- End-cleaned
- Delivered in sealed double plastic bag



Steinmeyer Mechatronik

Fritz-Schreiter-Straße 32

01259 Dresden

+49 351 88585-0

info@steinmeyer-mechatronik.de

www.steinmeyer-mechatronik.de